

WI Master.NET Control Unit

VERSIONE
2.6

Climatic regulation for centralized system

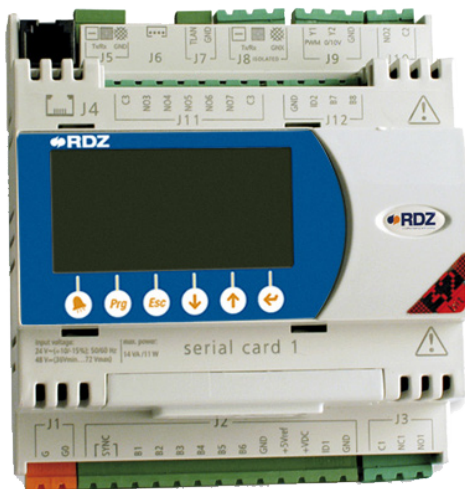

TECHNICAL MANUAL



SAFETY WARNINGS

SAFETY WARNINGS

Please, read this manual thoroughly before installation and/or use of the equipment and keep it in an accessible place.

The manufacturer's technical department is available at the phone numbers listed on the back of this manual for advice or particular technical requests.



ATTENTION

Installation and maintenance should be performed by qualified personnel only.

- Only use original spare parts: failure to comply with this norm can make the warranty null and void.

DISPOSAL



In accordance with the provisions of the following European directives 2011/65/EU, 2012/19/EU and 2003/108/EC, regarding reducing the use of hazardous substances in electrical and electronic equipment, in addition to waste disposal.

The barred bin symbol on the equipment indicates that at the end of its useful life it must be collected separately from other waste.

The user must therefore dispose of the equipment at the end of its useful life at the appropriate centres for the separate collection of electronic and electrical waste, or return it to the dealer when purchasing a new equivalent product, on a one to one basis.

Proper separate collection for subsequent recycling treatment and environmentally friendly disposal of the equipment helps prevent possible negative effects on health and the environment and promotes the recycling of the materials that make up the equipment.

Illegal dumping of the product by the user will result in the application of administrative sanctions according to the current law.



TABLE OF CONTENTS

| DESCRIPTION | PAGE |
|--|------|
| Presentation | 4 |
| Control unit operation panoramic diagram | 6 |
| Installation | 12 |
| Overview of the screens | 21 |
| Screen descriptions | 25 |
| Troubleshooting | 45 |
| Data tables | 47 |



PRESENTATION

The WI-NET control unit is one that can be used in managing peripheral units called SLAVES that periodically check a specific system. In its functionality, it is designed to service buildings with a centralised system. The unit is used for controlling production (boiler - chiller) and a main pump, for setting the season, for detecting the production temperature (TM) and finally for detecting the outdoor temperature (TE).

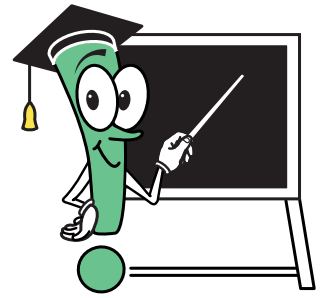

| Table A - FLASHING SYMBOLS | | |
|--------------------------------|------------------------|---|
| MOVING ICONS | | |
| When the cursor is blinking... | Pressing the button... | What happens is... |
| | | accesses the next screen |
| | | accesses the previous screen |
| | | accesses the fields to be modified within the current screen |
| | | returns to the previous menu |
| | or | accesses the following field (if present) |
| | | accesses the submenus |
| VALUE FIELDS | | |
| example: 24°C | | You can increase the value (e.g.: from "24°C" to "25°C") |
| | | You can decrease the value (e.g.: from "24°C" to "23°C") |
| | | You can confirm the value and proceed to the next field |
| TEXT FIELDS | | |
| example: Off/On | or | you can change the current setting (e.g.: from "ON" to "OFF") |
| | | You can confirm the value expressed by the text and proceed to the next field |

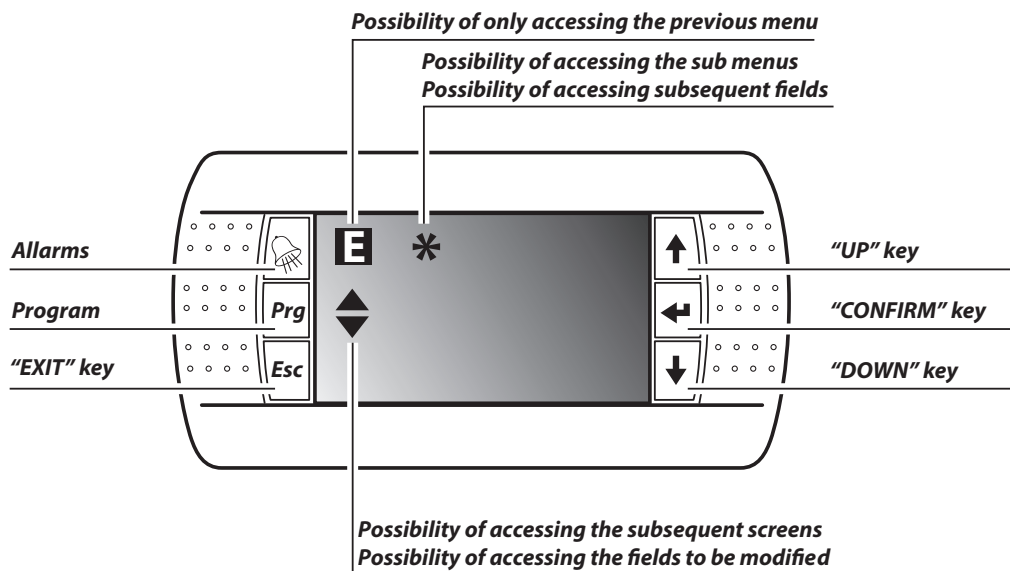

Table B - BUTTON FUNCTIONS

| Key | Function | | |
|-----|--|---|---|
| | The alarm button has a red backlight and is activated when the control system detects an anomaly. Pressing the button once will display the screen pertaining to the problem occurred. In the event of simultaneous alarms, these can be displayed by scrolling through the screens using the UP and DOWN buttons. Pressing this button again RESETS the alarms; should they still be present, the relative screens remain on display; otherwise the words "no alarm" will appear and the red backlight will turn off. | | |
| | Pressing the PRG button from the main screen displays the system time slot programming menu. Pressing the PRG button in any other context, will allow you to scroll through the progression of the displayed views and the various functions: System status / Set values / Readouts / Programming | | |
| | The "ESC" button takes you back to the previous menu without saving possible values that have been modified | | |
| Key | Moving icon function | Text field function (e.g.: ON/OFF) | Value field function (e.g.: 24.0°C) |
| | When the cursor * is blinking, it allows access to the following fields (if present) when the cursor ◆ is blinking it takes you to the previous screen | When the cursor is placed on a text field, this button changes the current setting value (e.g.: from "ON" to "OFF") | When the cursor is placed on a value field, this button will increase the value (e.g., from "24°C" to "25°C") |
| | When the cursor * is blinking, it allows you to access the submenus When the cursor ◆ is blinking, it allows you to access the fields to be modified in the screen | It confirms the value expressed by the text and proceeds to the next field | It confirms the value and proceeds to the next field. |
| | When the cursor * is blinking, it allows access to the following fields (if present) when the cursor ◆ is blinking, it takes you to the next screen | When the cursor is placed on a text field, this button changes the current setting value (e.g.: from "ON" to "OFF") | When the cursor is placed on a value field, this button will decrease the value (e.g., from "24°C" to "25°C") |



Table C - BUTTON COMBINATION FUNCTION

| BUTTON COMBINATION | ACTIVATION | FUNCTION | HARDWARE |
|--------------------|----------------------------------|--|----------------------------------|
| | At start up and during operation | Backlight control (increases contrast) | UI/E |
| | At start up and during operation | Backlight control (decreases contrast) | UI/E |
| | At start up and during operation | Historic system information and logs. | WI |
| | Upon start-up | Board address setting | WI-M1 WI-S2 WI-S3 WI-S4 |
| | During operation | Information menu: Type: Type of hardware Address: Board address Prg: type of program Vers: Program version | WI |



CONTROL UNIT OPERATION PANORAMIC DIAGRAM

Let's take a closer look to the symbols that summarise the general functions, connection to the local data bus and the elements connected to the unit.

Here is how the objects used later on are read:

Table E - Diagram key

| | | | |
|--|---|--|---|
| | Boiler <i>Digital output</i> | | Chiller <i>Digital output</i> |
| | Heat pump <i>Digital output</i> | | Mixing valve <i>Analogue output</i> |
| | Delivery Temperature Sensor <i>Analogue input (NTC)</i> | | System Pump <i>Digital output</i> |
| | Outdoor temperature sensor <i>Analogue input (NTC)</i> | | Season <i>Digital output</i> |
| | <i>Digital Input</i> | | Address <i>IU-PRO User Interface</i> |
| | Address <i>Slave Unit</i> | | Address <i>Primary Master / Secondary Master Unit</i> |



OPERATION MODE: MASTER

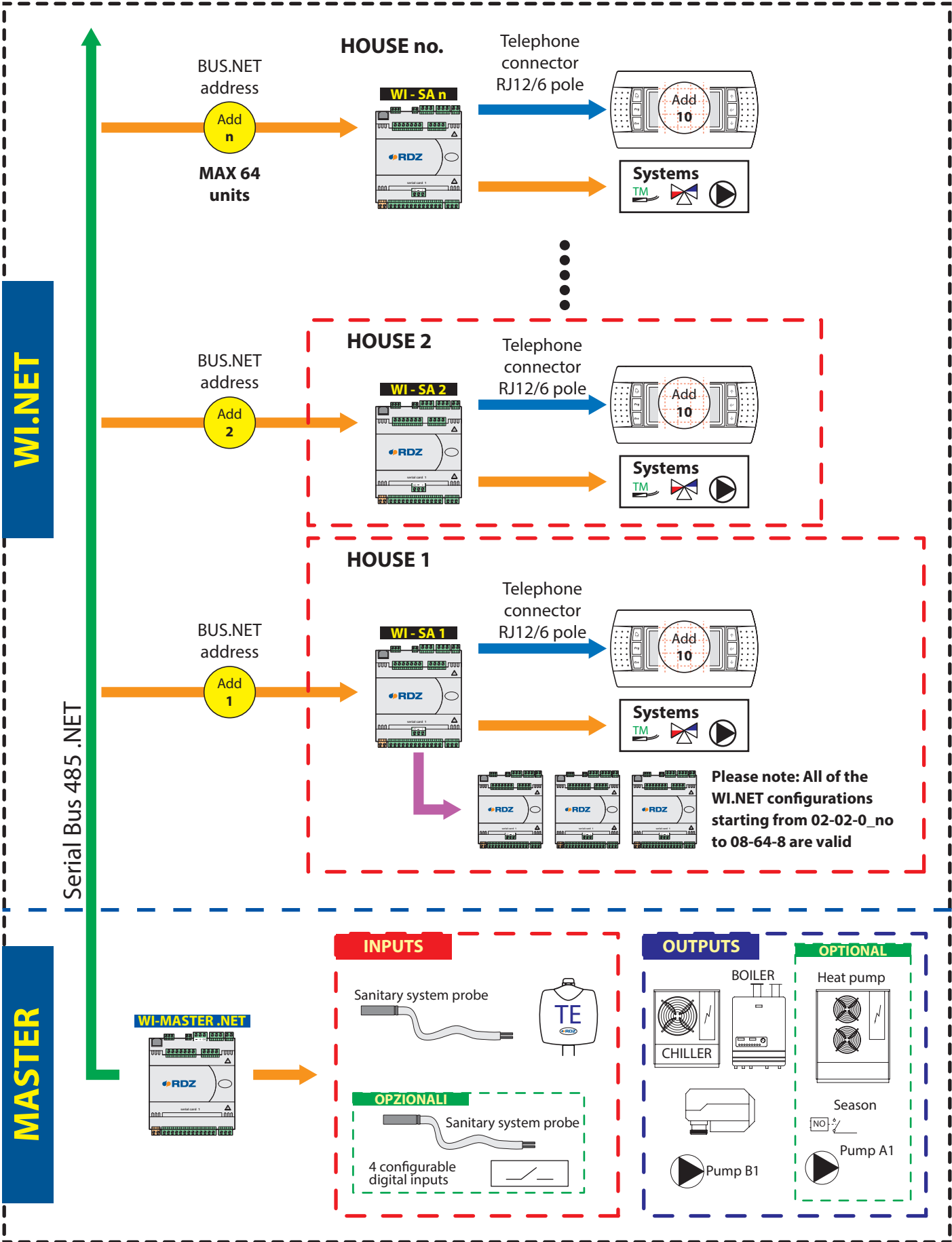



OPERATION MODE: MASTER-PC

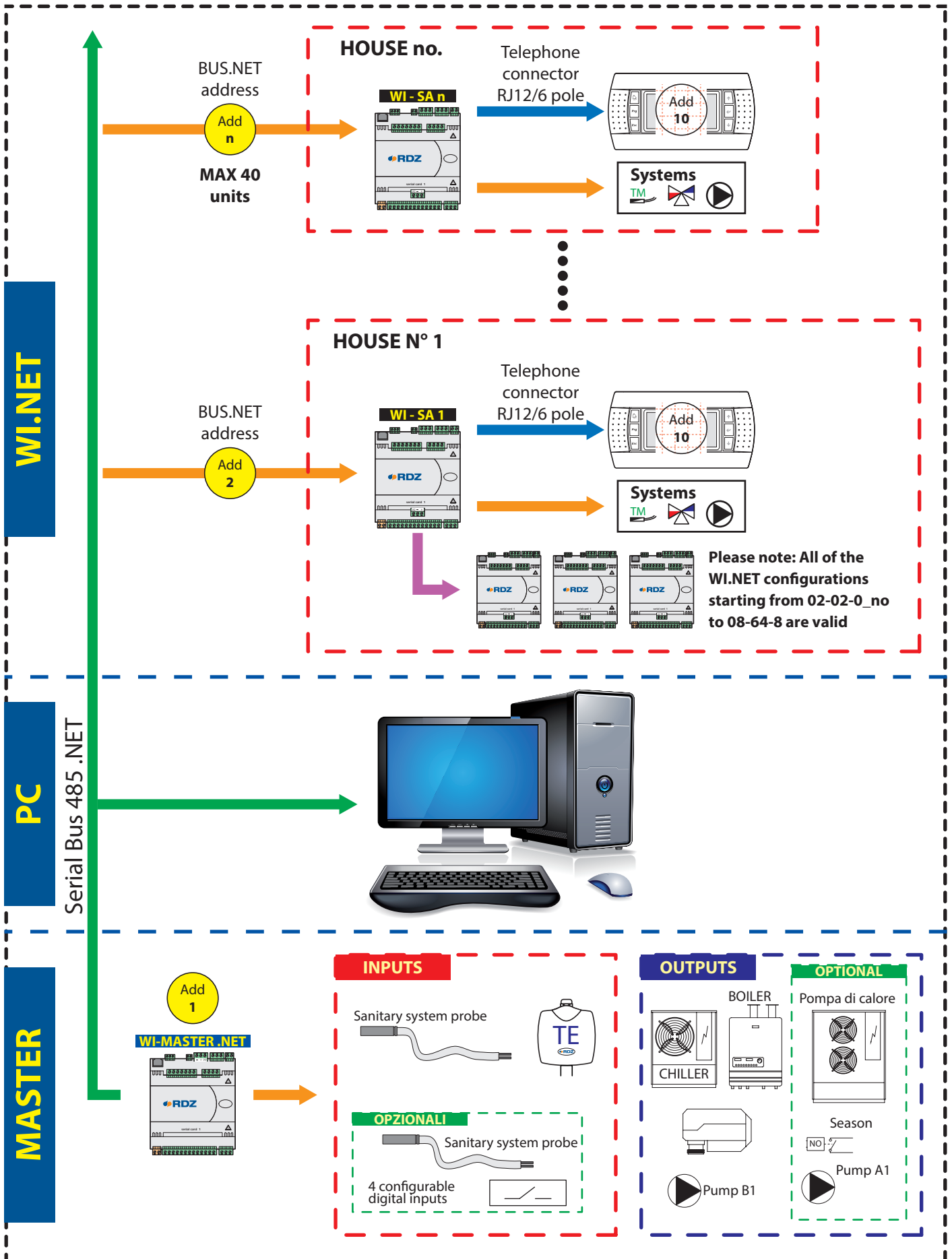



OPERATION MODE: MASTER-TRIO

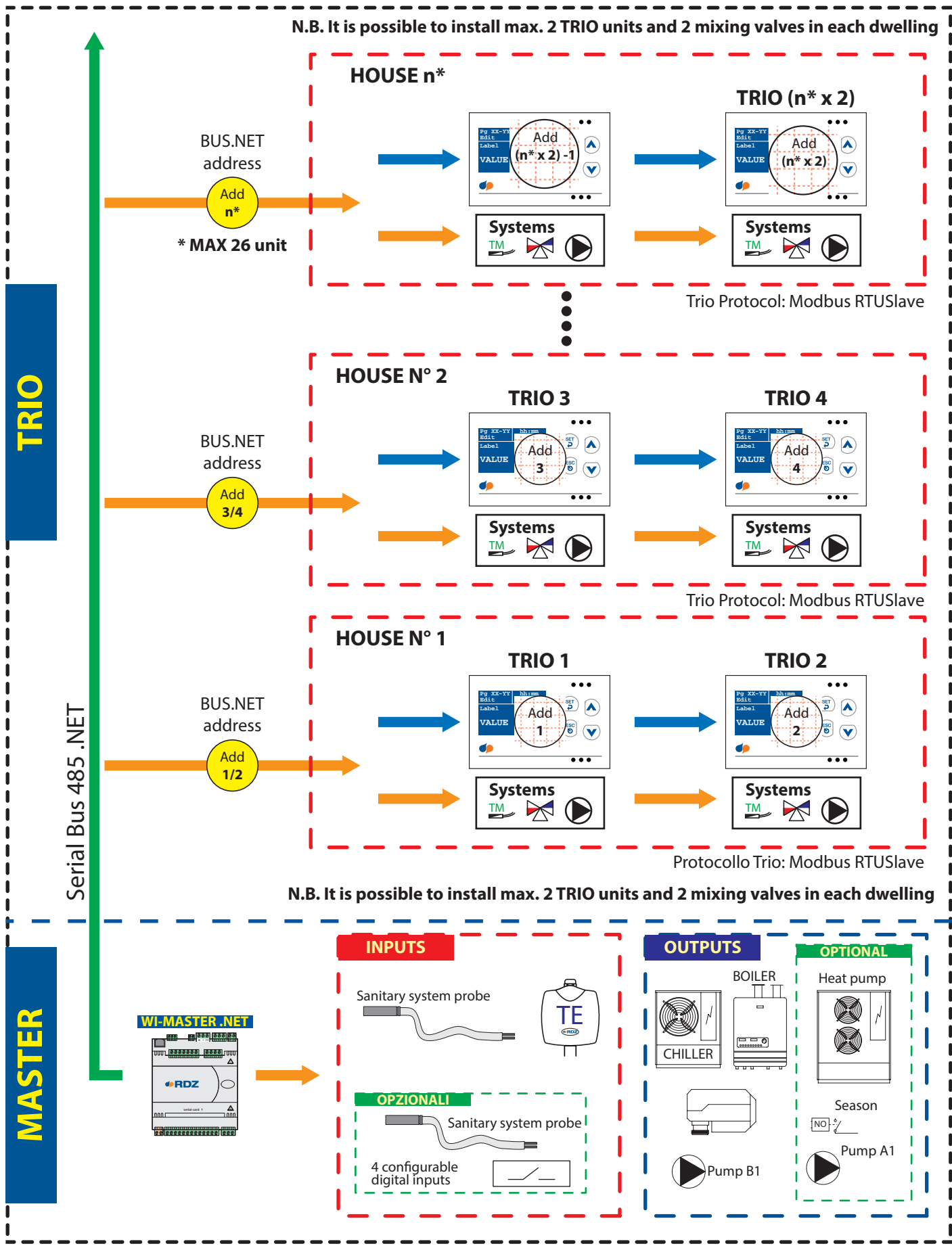



OPERATION MODE: MASTER-TCP

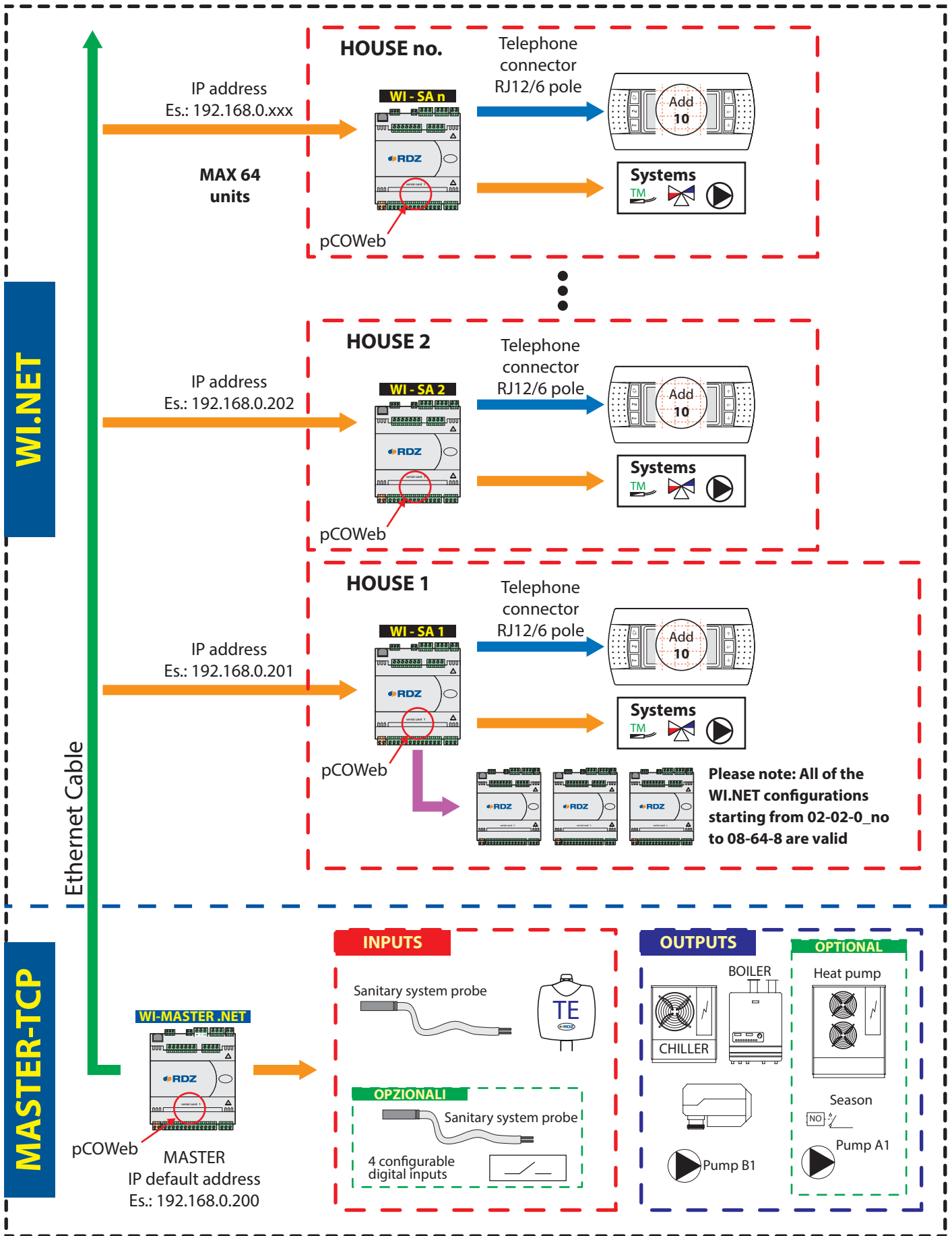



OPERATION MODE: MULTI - MASTER

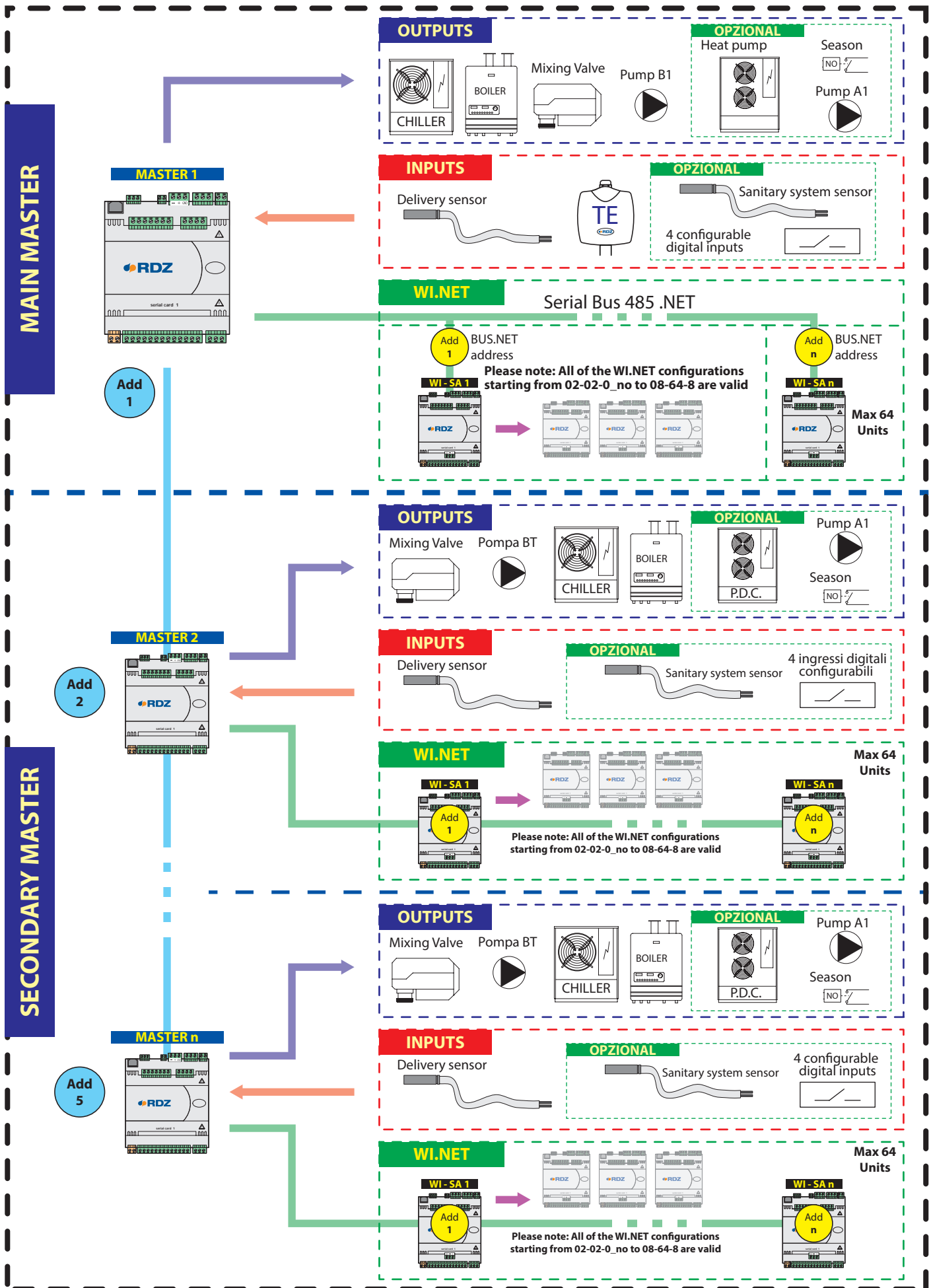



INSTALLATION

The control units come out by default with the software already configured for the pre-established connection
The main steps for configuring the system in the following modes are shown below:

- MASTER
- MASTER-PC
- MASTER-TRIO
- MASTER-TCP
- MULTI-MASTER.

MASTER

BUS CONNECTION

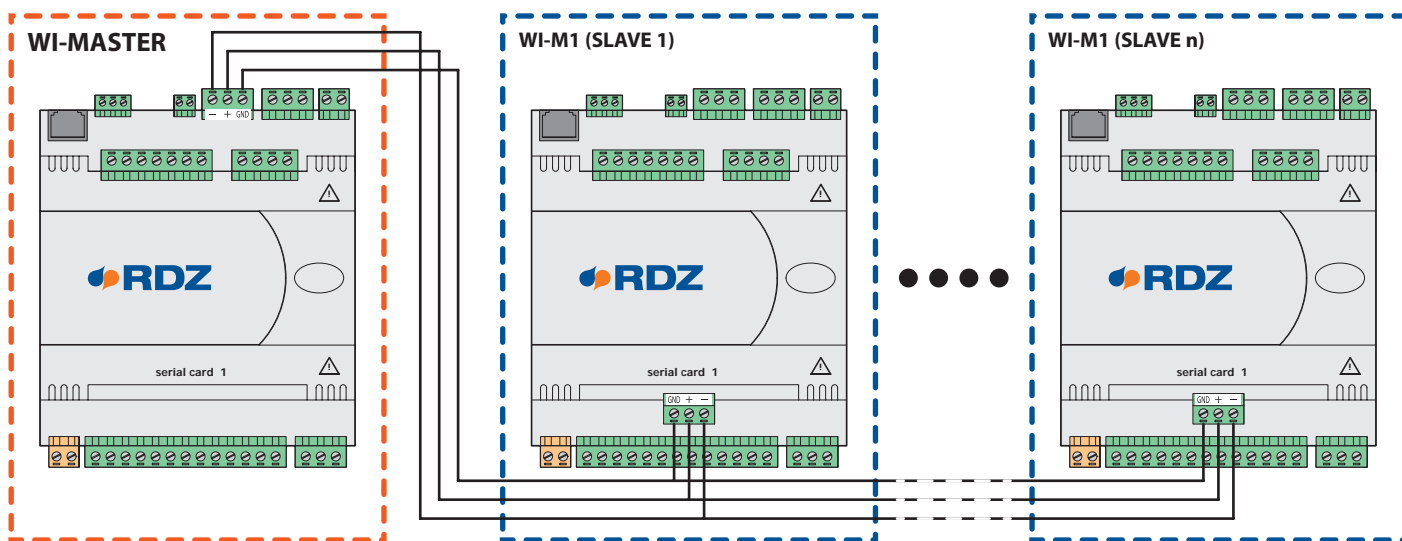

SLAVE CONFIGURATION

S1 SUPERVISOR SCREEN

```

S1 SUPERVISOR
1 Ident. No.:001 0
2 Spd.: 19200
3 Prot:3:MASTER RS485

Parameters
Serial Card 1

```

| Table of variables | |
|--------------------|--|
| Num | Description |
| 1 | Identification number of the slave unit: this value must be unique for each unit within the same configuration |
| 2 | Communication speed: 19200 (default) |
| 3 | Communication protocol: - set "MASTER RS485" for MASTER mode |

MASTER - SLAVE S1 SCREEN

```

MASTER -SLAVE S1
1 TimeOut: 03m 015m
2 Config.Slave:Master
3 Clock Master:Yes

Parameters
.net configuration

```

| Table of variables | |
|--------------------|--|
| Num | Description |
| 1 | TimeOut: Delay time between one MASTER communication and the other. |
| 2 | Config Slave: - set on "MASTER" |
| 3 | Clock Master: set to "Yes", all information regarding the clock will be communicated from the Master |



MASTER CONFIGURATION

1.2.1.2.4.1 - MASTER TYPE SCREEN

```

Master Type
1 Master Device:
  MASTER
2 Time OffLine:05min

```

| Table of variables | |
|--------------------|---|
| Num | Description |
| 1 | Type of master device: - MASTER the WI control unit is the master for the system - MASTER-PC the PC is the master for the system - MASTER-TRIO the WI control unit is the master for the system - MASTER-TCP the WI control unit is the master for the system |
| 2 | Delay time before defining the PC-MASTER offline |

1.2.1.2.4.6 - S2 SUPERVISOR SCREEN

```

S2 SUPERVISOR
FIELD-BUS [PORT 2]
1 F.B. Address:001
2 Speed:19200
3 Prot.:1:MAST. 485-(18)
4 F.B. Prot.:18

```

| Table of variables | |
|--------------------|--|
| Num | Description |
| 1 | Device address (must be 1) |
| 2 | Communication speed: |
| 3 | Communication protocol: - set "MAST". 485-(18)" for MASTER mode |
| 4 | Communication port (read only parameter) |

SLAVE DETECTION

The detection of the slave units can be done in 2 ways: manual or automatic.

MANUAL DETECTION

1.2.1.2.4.3 - MAX SLAVE UNIT SCREEN

In order to manually associate the slave unit you must first set the address of the slave unit with the highest value in the "MaxUnitId" field, then press the "PRG" button to access the screen, UNIT CONFIGURATION

```

Max SLAVE Unit
MaxUnitId:001
SLAVE CONFIGURATION
>>>>>>>>>>
Press Prg

```

1.2.1.2.4.3.1 - UNIT CONFIGURATION SCREEN

Using the "UP" and "DOWN" buttons you can move through the various slave units (from 1 to MaxUnitId previously set). Then, using the "PRESENT" field you can associate the unit selected with the master.

```

CONFIGURATION
UNIT:001
PRESENT: YES

```

AUTOMATIC DETECTION

1.2.1.2.4.24 - AUTOCONFIGURATION WIZARD SCREEN

To detect the slave unit automatically, just set the "Start" parameter to "Yes", at this point the master will start searching for all of the slave units that are connected and correctly configured.

```

AUTOCONFIGUR. Wiz
Start:No Poll:
          Cont:000
Step:STOP
N-Slave:000
MAX-Slave:001

```



MASTER - PC

BUS CONNECTION

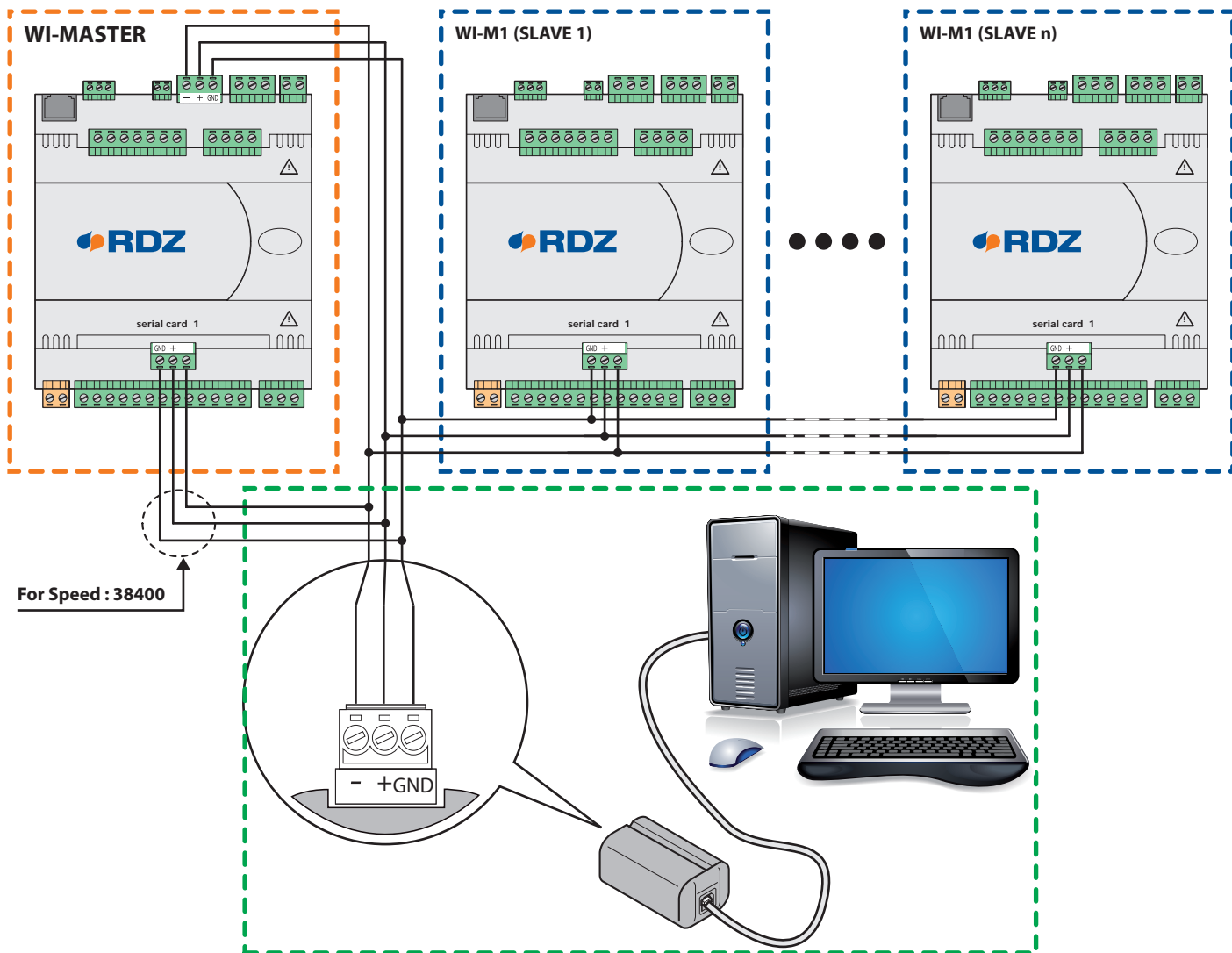

SLAVE CONFIGURATION

S1 SUPERVISOR SCREEN

```

S1 SUPERVISOR
1 Ident. No.:001 0
2 Spd.: 19200
3 Prot:3:ModBus Ext

Parameters
Serial Card 1

```

| Table of variables | |
|--------------------|--|
| Num | Description |
| 1 | Identification number of the slave unit: this value must be unique for each unit within the same configuration |
| 2 | Communication speed: 19200 (default) |
| 3 | Communication protocol: - set "Modbus Ext" for the MASTER-PC mode |



MASTER - SLAVE S1 SCREEN

```

MASTER -SLAVE S1
1 TimeOut: 03m 015m 2
3 Config.Slave:Master_PC
4 Clock Master:Yes

Parameters
.net configuration

```

| Table of variables | |
|--------------------|--|
| Num | Description |
| 1 | TimeOut: Delay time between one communication and another between PC and slave unit |
| 2 | Total communication time between the PC and all slaves |
| 3 | Config Slave: - set on "MASTER-PC" |
| 4 | Clock Master: set to "Yes", all information regarding the clock will be communicated from the Master |

MASTER CONFIGURATION

1.2.1.2.4.1 - MASTER TYPE SCREEN

```

Master Type
1 Master Device:
   MASTER-PC
2 Time OffLine:05min

```

| Table of variables | |
|--------------------|---|
| Num | Description |
| 1 | Type of master device: - set on MASTER-PC |
| 2 | Set the delay time before defining the PC offline (default 5 min) |

1.2.1.2.4.6 - S2 SUPERVISOR SCREEN

```

S2 SUPERVISOR
FIELD-BUS [PORT 2]
1 F.B. Address:001
2 Speed:19200
3 Prot.:3:ModB. Ext (50)
4 F.B. Prot.:18

```

| Table of variables | |
|--------------------|--|
| Num | Description |
| 1 | Device address (must be 1) |
| 2 | Communication speed: |
| 3 | Communication protocol: - set "3:ModB. Ext (50)" if in MASTER-PC mode |
| 4 | Communication port (read only parameter) |

SLAVE DETECTION

The detection of the slave units can be done in 2 ways: manual or automatic.

MANUAL DETECTION

1.2.1.2.4.3 - MAX SLAVE UNIT SCREEN

In order to manually associate the slave unit you must first set the address of the slave unit with the highest value in the "MaxUnitId" field, then press the "PRG" button to access the screen, UNIT CONFIGURATION

```

Max SLAVE Unit
MaxUnitId:001

SLAVE CONFIGURATION
>>>>>>>>>>
Press Prg

```

1.2.1.2.4.3.1 - UNIT CONFIGURATION SCREEN

Using the "UP" and "DOWN" buttons you can move through the various slave units (from 1 to MaxUnitId previously set). Then, using the "PRESENT" field you can associate the unit selected with the master.

```

CONFIGURATION
UNIT:001

PRESENT: YES

```



MASTER-TRIO

BUS CONNECTION

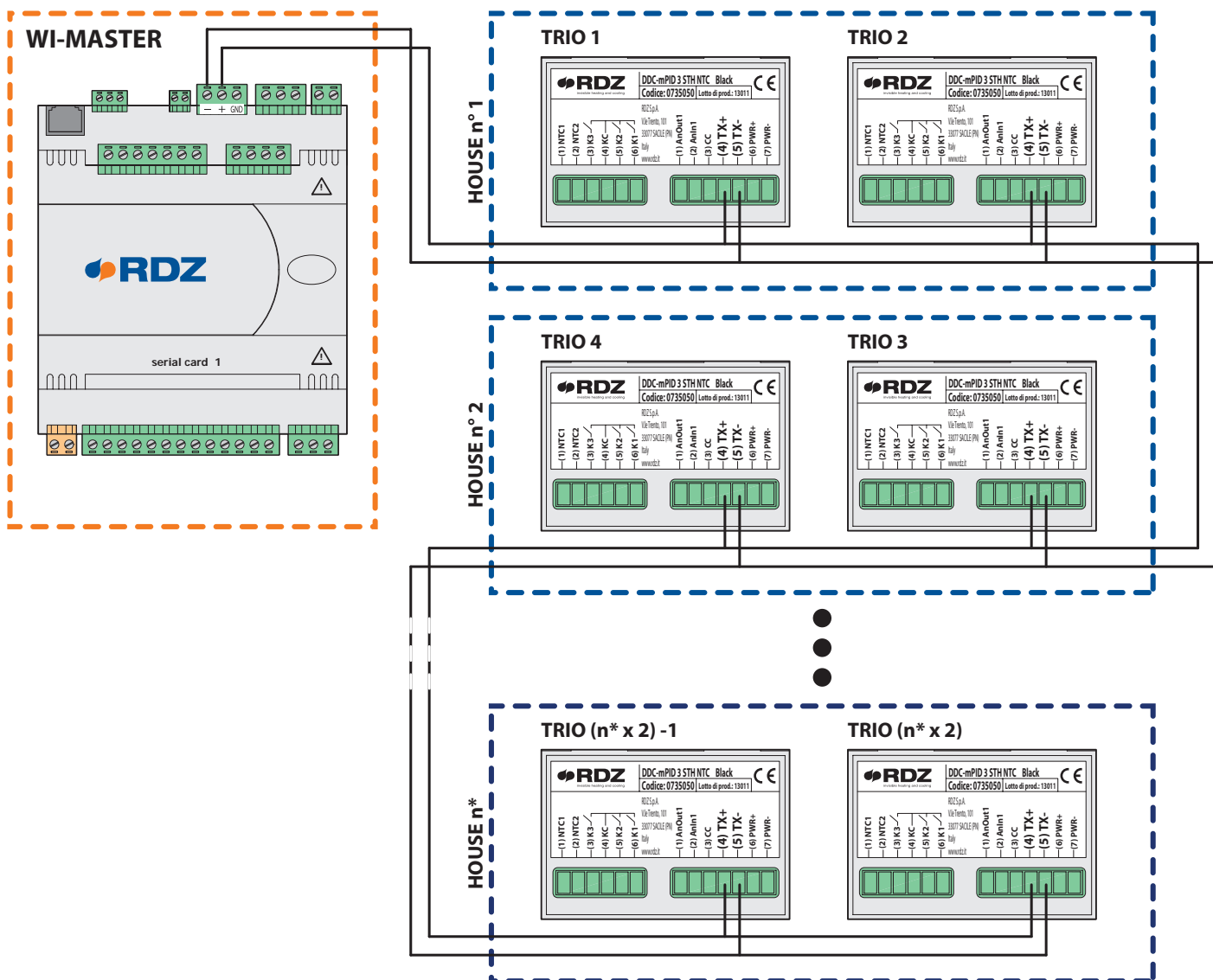

CONFIGURAZIONE TRIO

PASSWORD ENTERING AND ACCESSING THE TECHNICAL MENU

From the main menu, it is possible to access the technical menu by pressing and holding (>5 sec) + .

Then, when you are required to enter the access password use the following combination of keys:



By pressing the last key, you can access the technical menu.

With and it is possible to browse through the fields of the menu.



PROCEDURE TO EDIT PARAMETERS

To edit the highlighted field, briefly press . Use and to set the desired value. is used to confirm the value (Enter) and go back to the main page.

TYPE PARAMETER

| Label | Description | Min | Max | Default |
|-------|---|-----|-----|---------|
| Type | It identifies the controller operating mode | 0.0 | 5.0 | 0.0 |

Set at 0.0 for system without mixing valve

Set at 1.0 for system with mixing valve

n.b.: values different from 0.0 and 1.0 will be not accepted.



SLAVE PARAMETER

| Label | Description | Min | Max | Default |
|-------|------------------------------|-----|-----|---------|
| Slave | Controller set in Slave mode | 0.0 | 1.0 | 0.0 |

Set value at **1.0**

ONOFFBYMASTER PARAMETER

| Label | Description | Min | Max | Default |
|---------------|-------------------------------------|-----|-----|---------|
| OnOffByMaster | Centralized on/off from Master unit | 0.0 | 1.0 | 0.0 |

ACCESSING THE CONFIGURATION MENU

From the main menu, it is possible to access the configuration menu by pressing and holding (>5 sec) + , then use and to browse through the various items of the menu.

PROCEDURE TO EDIT PARAMETERS

To edit the parameters, go to the desired entry and briefly press

Use and to change the set value and select the desired one.

is used to confirm the selection (Enter) and go back to the home page.



ADDRESS PARAMETER

| Label | Description | Min | Max | Default |
|---------|----------------|-----|-------|---------|
| Address | Device Address | 1.0 | 247.0 | 1.0 |

Set device address value according to the flat and relevant zones.

By using the following formula you can work out the exact value to be set:

$$\text{Address ZONE 1} = (n^{\circ} \text{ Flat} - 1) \times 2 + 1$$

$$\text{Address ZONE 2} = (n^{\circ} \text{ Flat} - 1) \times 2 + 2$$

| Example data chart | | |
|--------------------|----------------|----------------|
| HOUSE Number | ZONE 1 Address | ZONE 2 Address |
| 1 | 1 | 2 |
| 2 | 3 | 4 |
| 3 | 5 | 6 |
| 4 | 7 | 8 |
| | | |
| 26 | 51 | 52 |

BAUDRATE PARAMETER

| Label | Description | Value | Default |
|----------|---------------------|--|---------|
| Baudrate | Communication speed | 9600 19200 38400 57600 115200 | 115200 |

Set value at **19200**

PROTOCOL PARAMETER

| Label | Description | Value | Default |
|----------|------------------------|---|---------|
| Protocol | Communication protocol | Newthom Modbus RTUMaster Modbus RTUSlave | Newtohm |

Set value on **Modbus RTUSlave**



MASTER CONFIGURATION

1.2.1.2.4.1 - MASTER TYPE SCREEN

```

Master Type
① Master Device:
    MASTER-TRIO
② Time OffLine:05min

```

| Table of variables | |
|--------------------|---|
| Num | Description |
| ① | Type of master device: - set on MASTER-TRIO (the WI control unit is the master for the system) |
| ② | Set the delay time before defining the PC offline (default 5 min) |

1.2.1.2.4.6 - S2 SUPERVISOR SCREEN

```

S2 SUPERVISOR
FIELD-BUS [PORT 2]
① F.B. Address:001
② Speed:19200
③ Prot.:2:ModB. Mas-(21)
④ F.B. Prot.:21

```

| Table of variables | |
|--------------------|---|
| Num | Description |
| ① | Device address (must be 1) |
| ② | Communication speed: |
| ③ | Communication protocol, set: "2:ModB. Mas-(21)" if in MASTER-TRIO mode |
| ④ | Communication port (read only parameter) |

SLAVE DETECTION

The detection of the slave units can be done in 2 ways: manual or automatic.

MANUAL DETECTION

1.2.1.2.4.3 - MAX SLAVE UNIT SCREEN

In order to manually associate the slave unit you must first set the address of the slave unit with the highest value in the "**MaxUnitId**" field, then press the "**PRG**" button to access the screen, UNIT CONFIGURATION

```

Max SLAVE Unit
MaxUnitId:001

SLAVE CONFIGURATION
>>>>>>>>>>
Press Prg

```

1.2.1.2.4.3.1 - UNIT CONFIGURATION SCREEN

Using the "**UP**" and "**DOWN**" buttons you can move through the various slave units (from **1** to **MaxUnitId** previously set). Then, using the "**PRESENT**" field you can associate the unit selected with the master.

```

CONFIGURATION
UNIT:001

001
1° Zone PRESENT: Yes
002
2° Zone PRESENT: No

```



MASTER-TCP

LAN CONNECTION

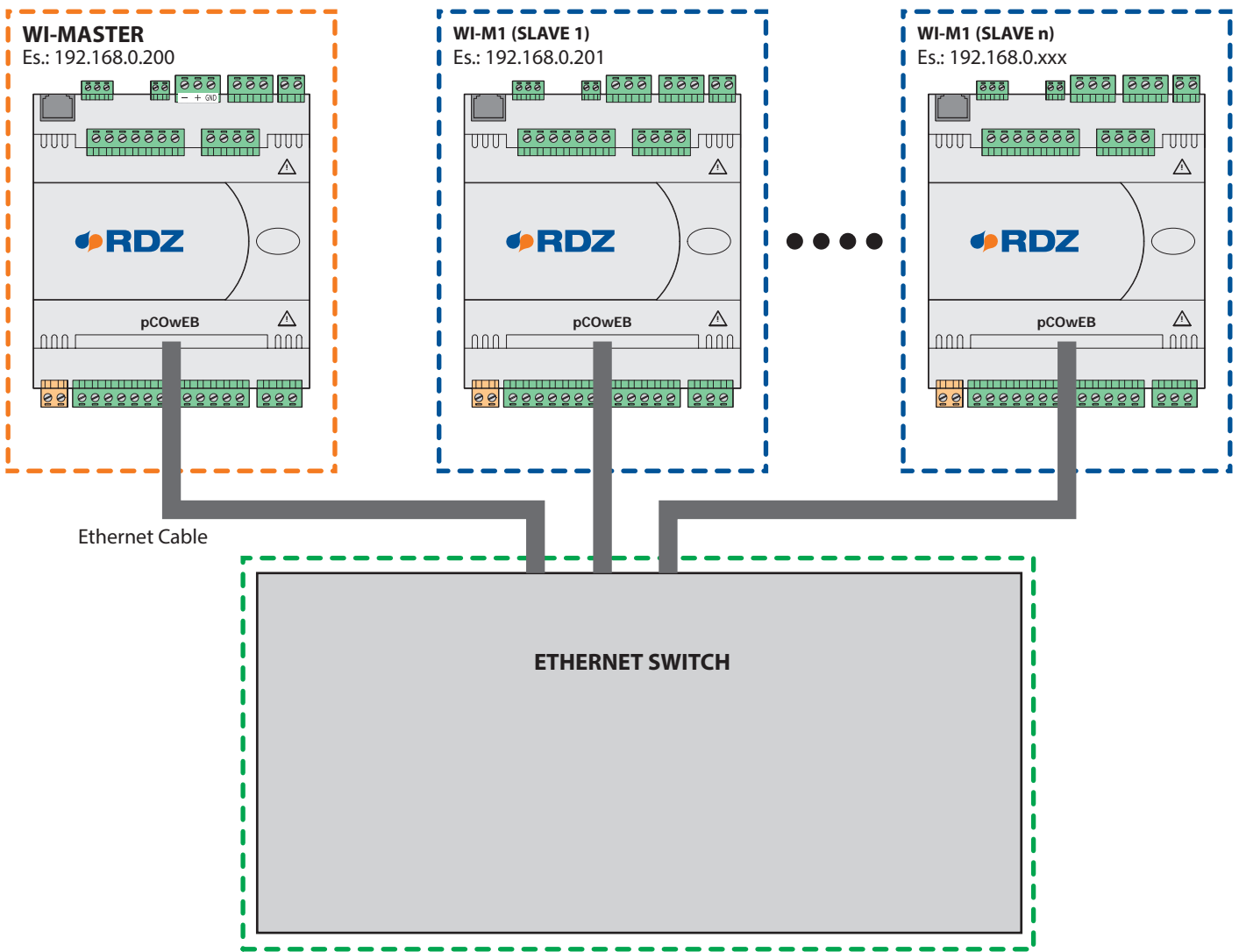

MASTER IP ADDRESS CONFIGURATION

Refer to the pCOWeb manual.



SLAVE DETECTION

To configure the connected slaves on the Master it is necessary to connect Master device with an internet browser. (For how to connect and to change the IP address of the Master, refer to the pCOWeb manual).

Click on the icon labeled NET (Master Slave Configuration) (Fig. 1) and enter User: "admin" and Password: "0123" to access the Slave configuration page (Fig. 2).

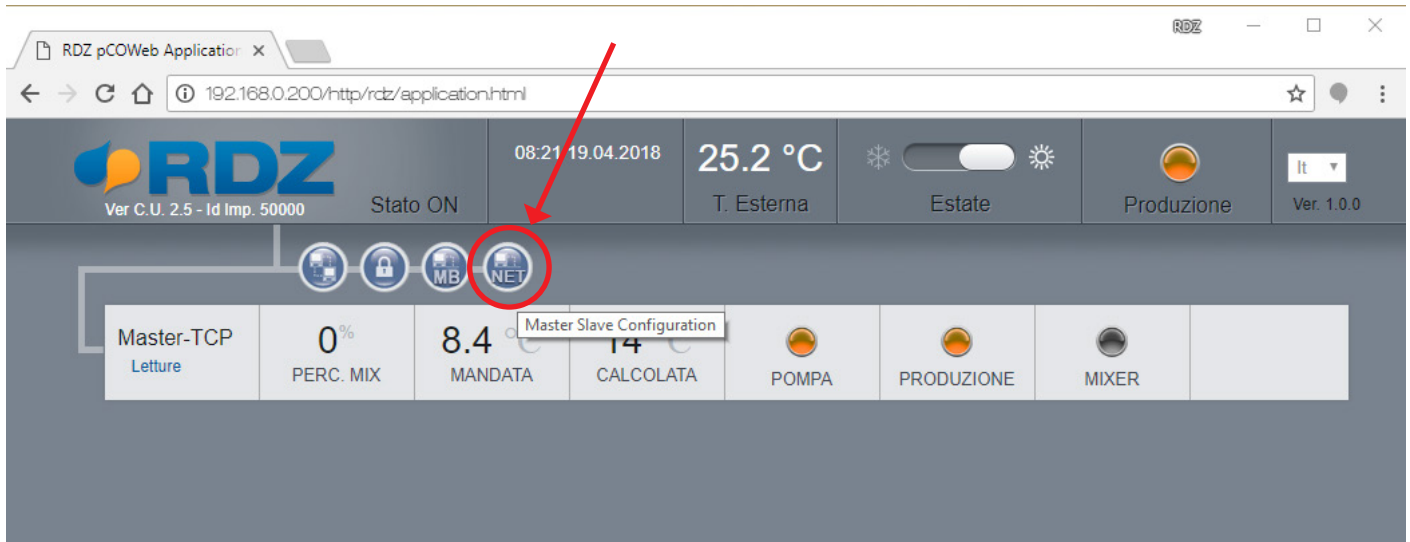

Fig. 1

Click "Modify" and enter each of the IP addresses configured in the slaves, then press Enter or click "Submit" at the bottom of the page (For the connection modes and for changing the IP address of the Slaves refer to the pCOWeb manual) .

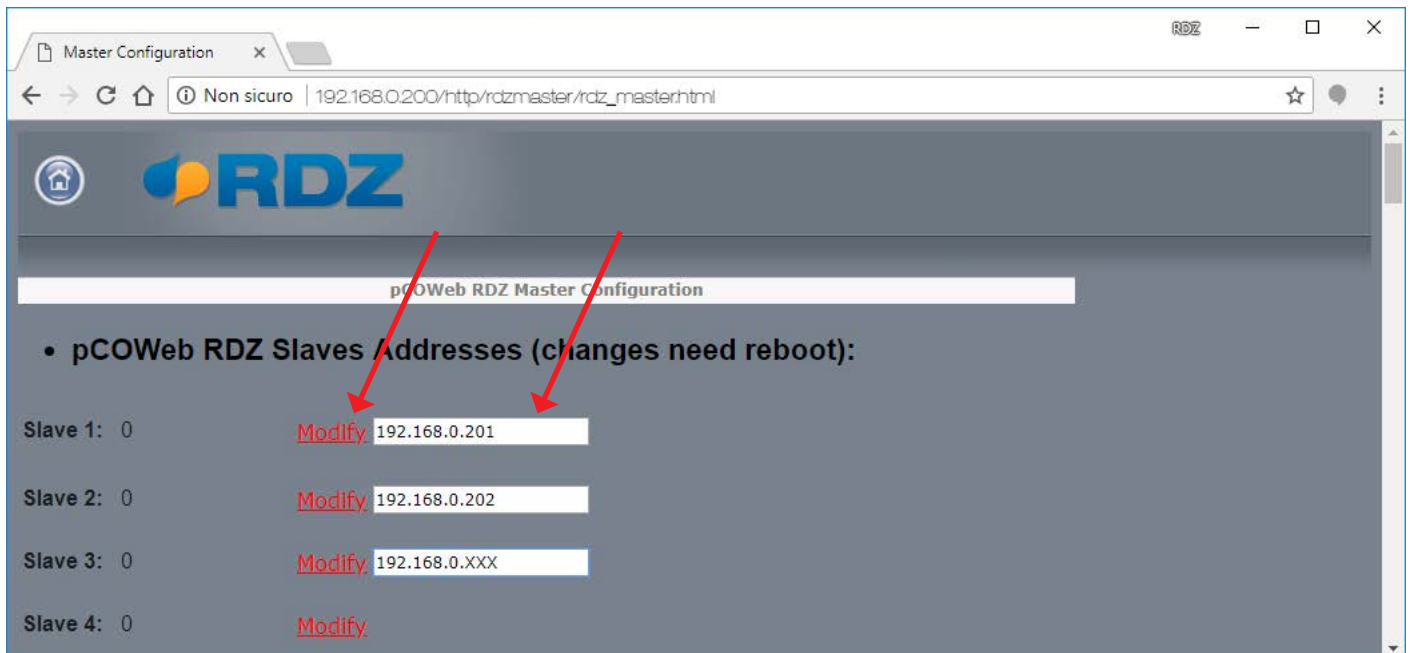

Fig. 2



Then click on “Reboot” (Fig. 3) to restart the pCOWeb (Fig. 4), and apply the changes, after about 1 minute the main page will be displayed automatically (Fig. 1).

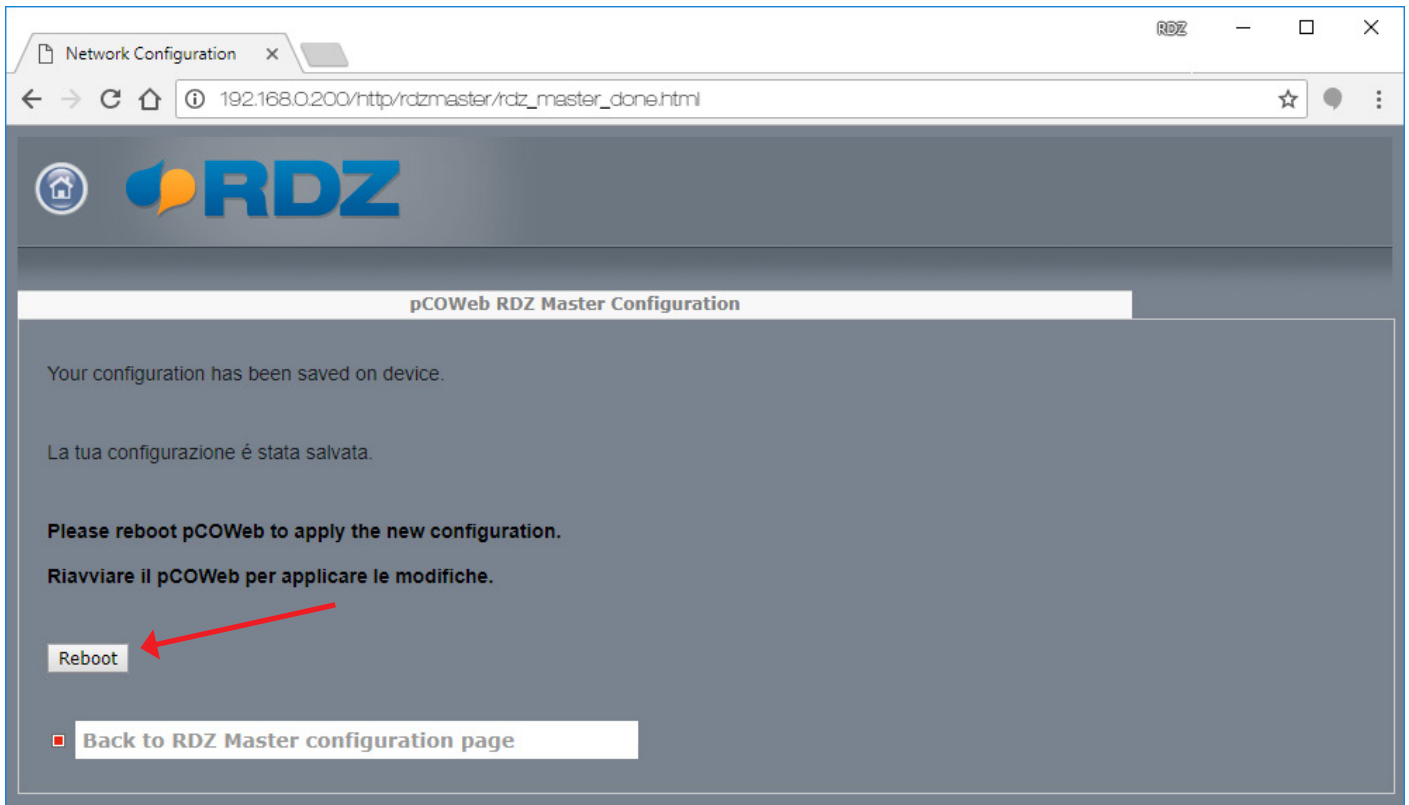

Fig. 3

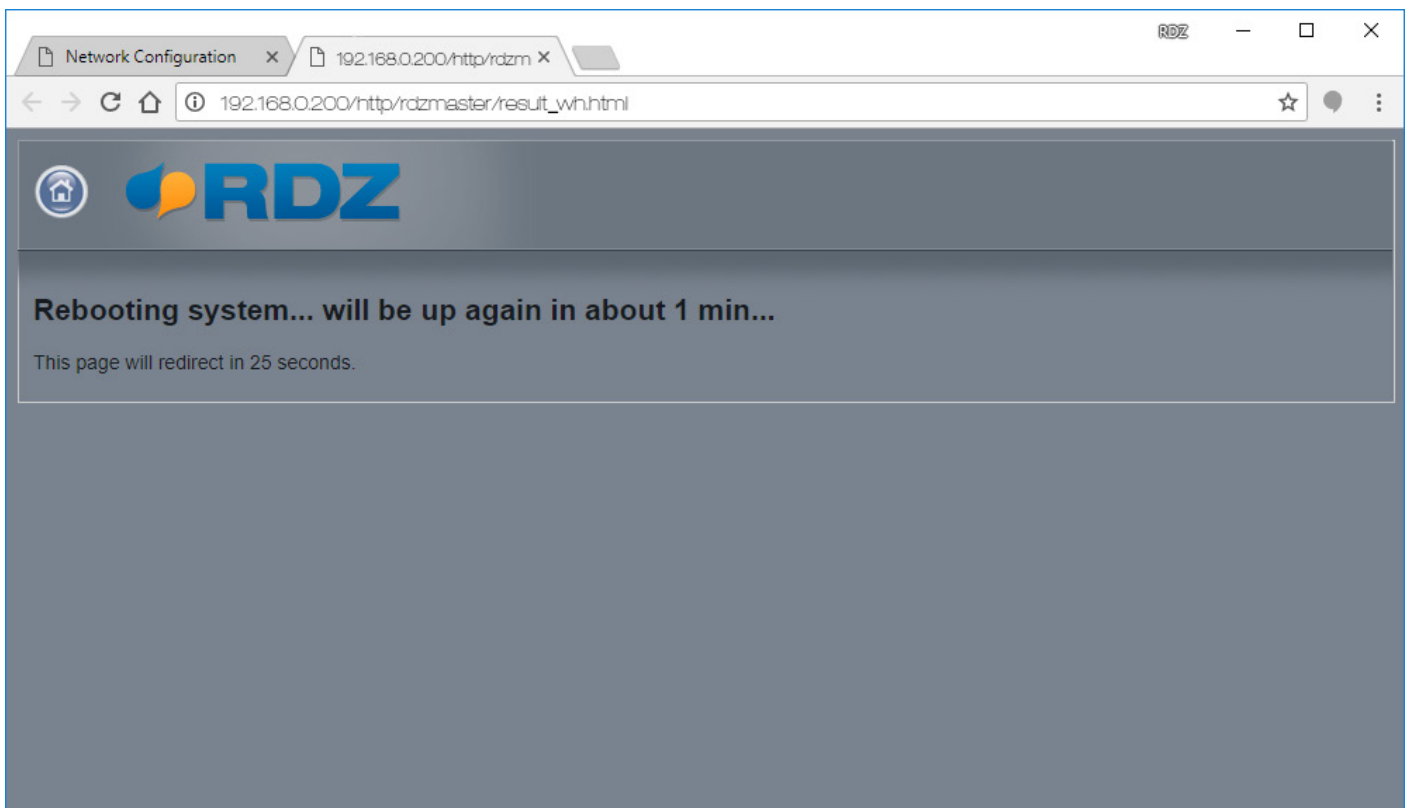
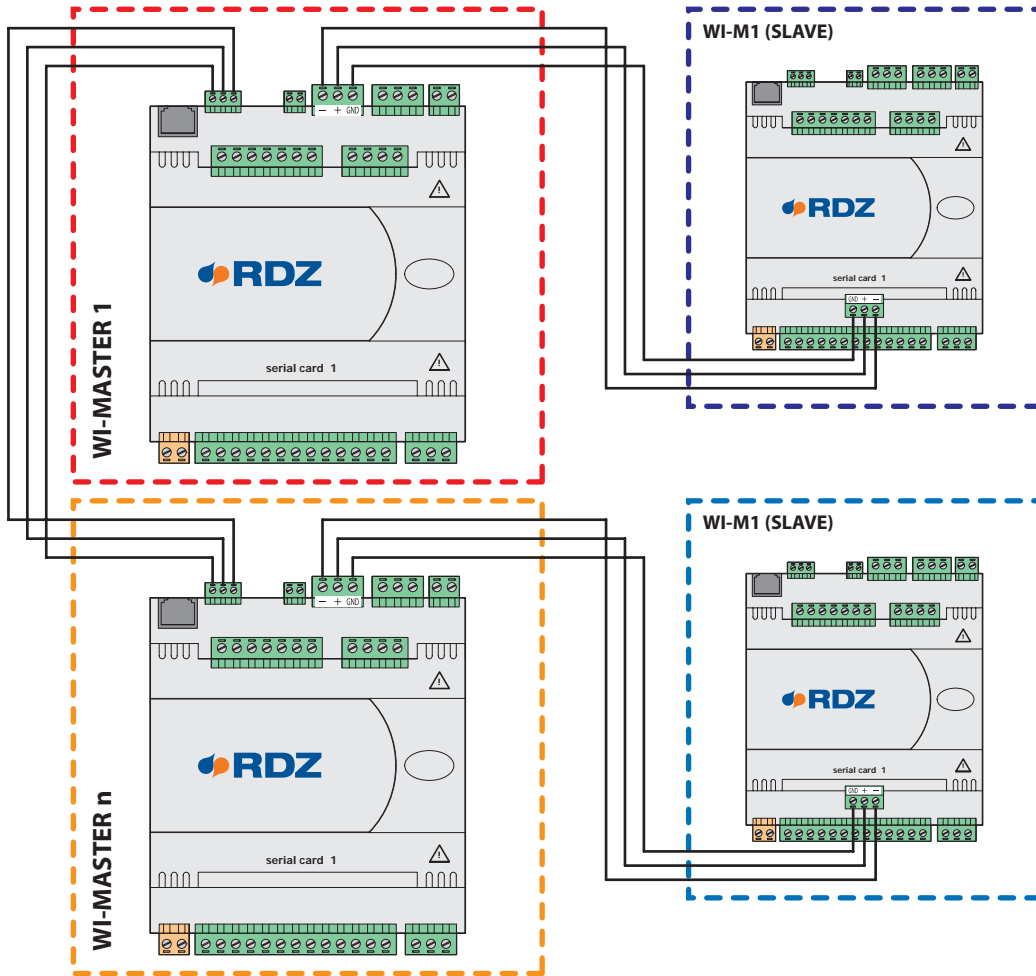

Fig. 4



MULTI - MASTER

BUS CONNECTION



CHANGE THE UNIT'S NETWORK ADDRESS

Bus RJ12 /pole6 poli

Address 0

OFF

ON

pLan address: 1
UP: increase
DOWN: decrease
ENTER: save & exit

Address table

| Unit | Address |
|----------|---------|
| Master 1 | 1 |
| Master 2 | 2 |
| Master 3 | 3 |
| Master 4 | 4 |
| Master 5 | 5 |

Proceed as follows:

- 1) Prepare a UI/PRO terminal with address 0 and connect it to the central unit by means of an RJ12 cable
- 2) Disconnect the power supply from the WI-XX unit
- 3) Power the WI-M1/Sx unit
- 4) press the **Alarm + Up** buttons at the same time. After a few seconds you will see screen 5)
- 6) If you wish to change the address, use the **Up Down** buttons and then press **Enter** to confirm.



CONFIGURING THE IU-PRO ADDRESSES

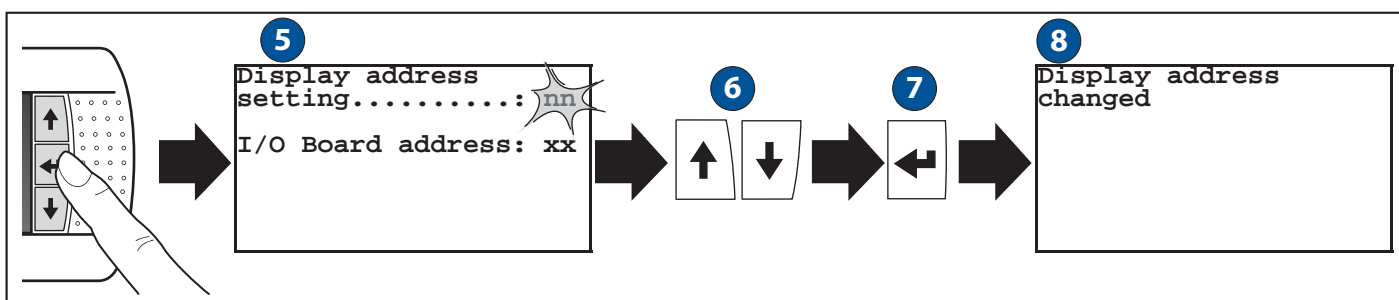
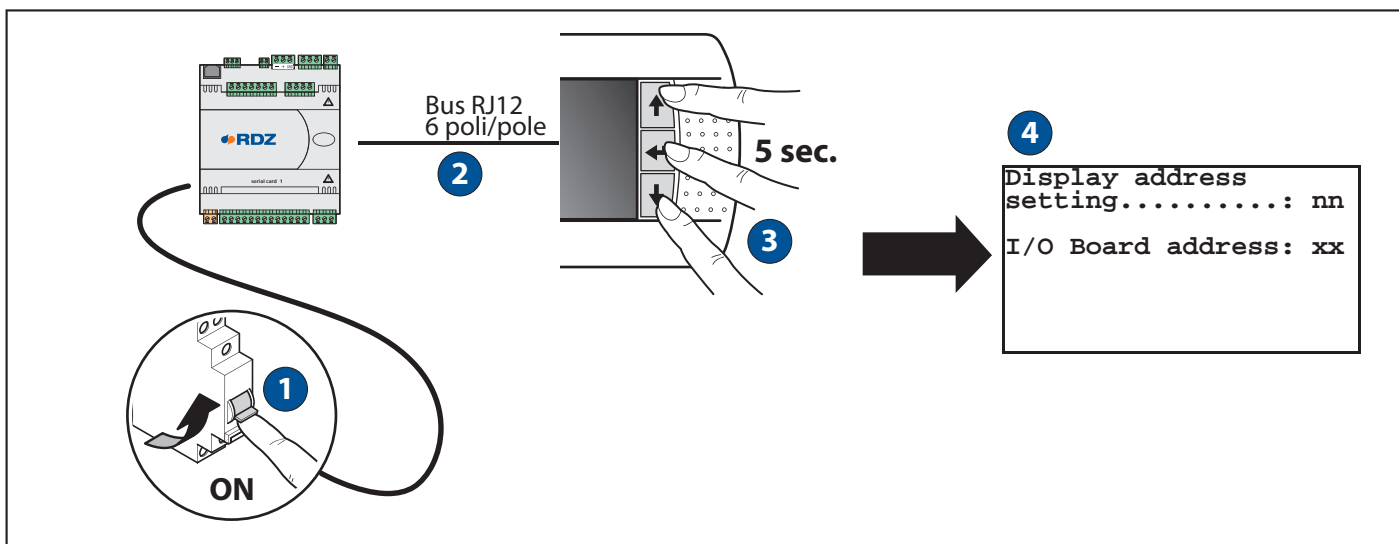

Proceed as follows:

- 1) Power on;
- 2) Prepare a UI/PRO terminal with and connect it to the central unit by means of an RJ12 cable;
- 3) to enter configuration mode, hold down the **Up** **Enter** **Down** buttons at the same time for at least 5 seconds;
- 4) once this is complete, screen 4) will appear on the terminal.
- 5) To modify the terminal address, press the **Enter** button, the cursor will be positioned on the address field (nn).
- 6) Using the **Up** **Down** buttons, select the address desired.
- 7) Confirm the address using the **Enter** button. (Screen "8" appears if the parameters are modified, otherwise mask "9" appears).

| Legend | |
|--------|---|
| Num | Description |
| 1 | Name of the terminals (Cannot be edited) |
| 2 | Address of the terminals |
| 3 | Terminal functions Pr: Private Sh: shared Sp: Print (not available) |
| 4 | NO: return to the address for terminal Trm1 YES: exit confirming the new configuration |

| IU-PRO address table | | | |
|----------------------|----------|---------|-------------|
| Unit | Terminal | Address | Priv/Shared |
| Master 1 | trm1 | 10 | Pr |
| | trm2 | - | - |
| | trm3 | 32 | Sh |
| Master 2 | trm1 | 11 | Pr |
| | trm2 | - | - |
| | trm3 | 32 | Sh |
| Master 3 | trm1 | 12 | Pr |
| | trm2 | - | - |
| | trm3 | 32 | Sh |
| Master 4 | trm1 | 13 | Pr |
| | trm2 | - | - |
| | trm3 | 32 | Sh |
| Master 5 | trm1 | 14 | Pr |
| | trm2 | - | - |
| | trm3 | 32 | Sh |

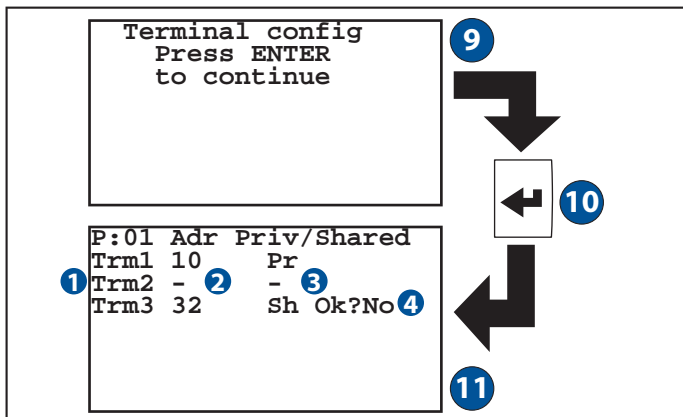

- 10) press **Enter** to access the network address change;
- 11) change the parameters as shown in the table;



OVERVIEW OF THE SCREENS

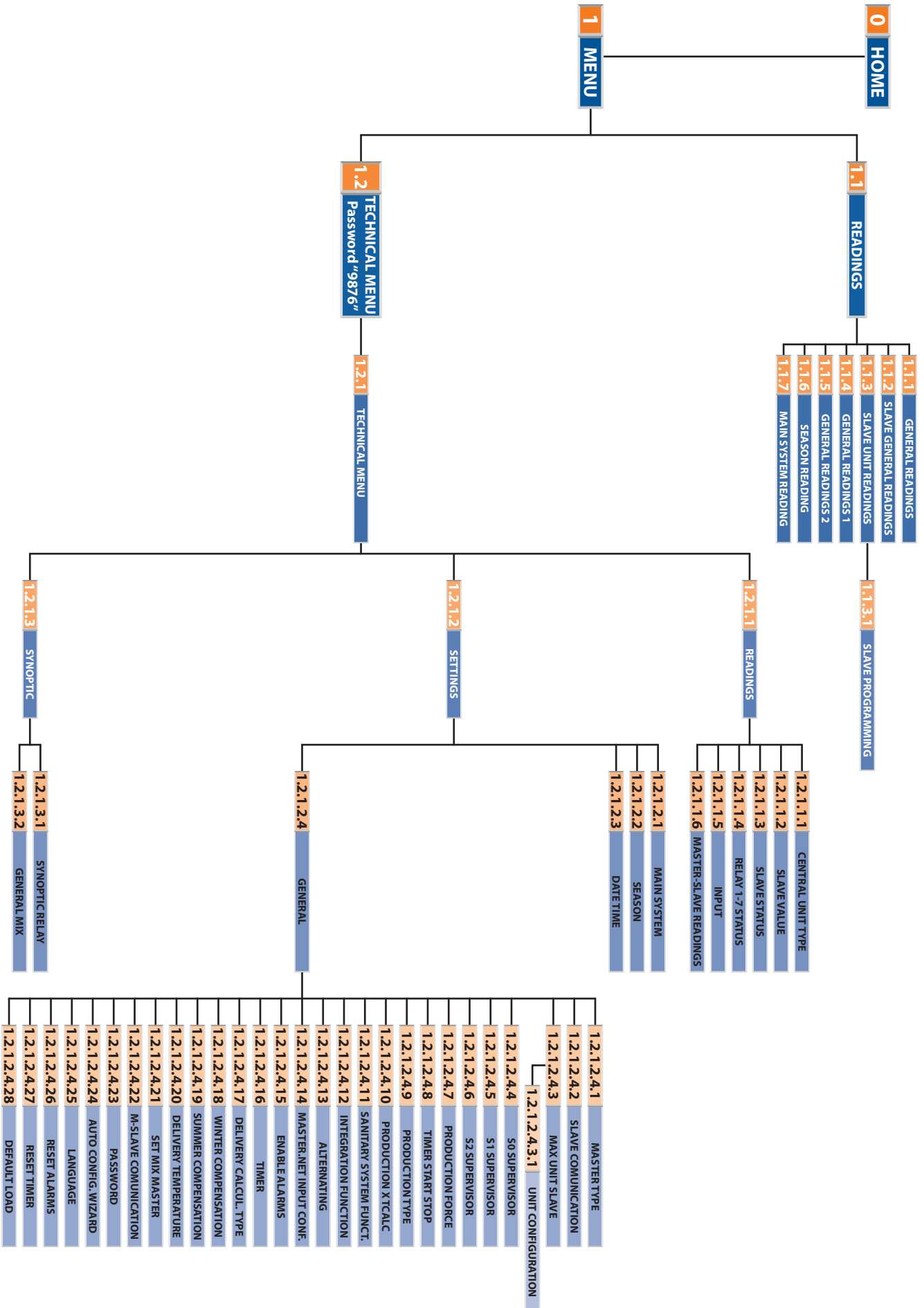



SCREEN DESCRIPTIONS

0

MAIN SCREEN

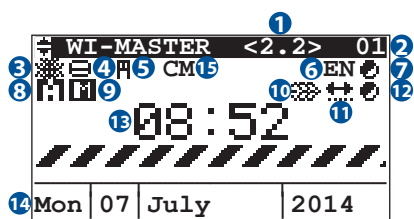

| Table of variables | |
|--------------------|--|
| Num | Description |
| 5 | High temperature request |
| 6 | Set language |
| 7 | HT production status |
| 8 | Anti-freeze |
| 9 | M=master (address Plan=1) S=slave (address Plan≠1) |
| 10 | It flashes each time there is data sent between the control unit and another device (PC, Slave or external Supervisor). |
| 11 | This icon indicates that a connection was made between the control unit and another device (PC, Slave or supervisor). If it is visibly flashing there is a communication error |
| 12 | LT production status |
| 13 | Current Time |
| 14 | Current Date |
| 15 | CM = Master; PC = MASTER-PC; TRIO = MASTER-TRIO; TCP = MASTER-TCP |

| Table of variables | |
|--------------------|--|
| Num | Description |
| 1 | Software version |
| 2 | Master ID |
| 3 | Operating season: ☀ Summer ❄ Winter |
| 4 | General activation status: ☑ Active ☐ Inactive |

1

MENU SCREEN



| Table of movements | | |
|--------------------|--------|---------------------------|
| Key | Screen | |
| Esc | 0 | MAIN |
| ↑ | 0 | MAIN |
| ← + ← | 1.1.1 | GENERAL READINGS |
| ← + ↓ + ← | 1.2 | TECHNICAL MENU - PASSWORD |

ADDRESS 1 MENU / 1.1 READINGS /

1.1.1

GENERAL READINGS SCREEN

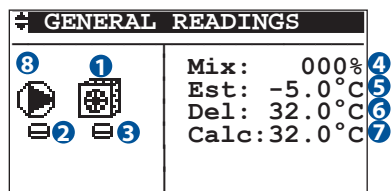

| Table of variables | |
|--------------------|---|
| Num | Description |
| 1 | Type of generator used - chiller - boiler |
| 2 | Activation status of the main pump: ☑ Activated ☐ Deactivated |
| 3 | Activation status of production: ☑ Activated ☐ Deactivated |
| 4 | Mixing valve opening percentage |
| 5 | Exterior temperature detected |
| 6 | Delivery temperature detected |
| 7 | Delivery temperature calculated |
| 8 | Slave index |

| Table of movements | | |
|--------------------|--------|---|
| Key | Screen | |
| Esc | 1 | MENU |
| ↑ | 1.1.7 | MAIN SYSTEM |
| ↓ | 1.1.2 | SLAVE GENERAL READINGS (In MASTER-PC mode data are not shown) |
| | 1.1.3 | SLAVE UNIT READINGS (If in MASTER or MASTER-TRIO mode) |
| | 1.1.4 | GENERAL READINGS 1 |



1.1.2 SLAVE GENERAL READINGS SCREEN

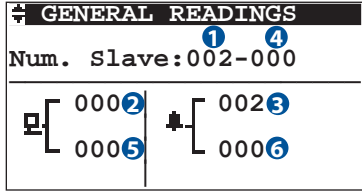

| Table of variables | |
|--------------------|---|
| Num | Description |
| 1 | Number of flats involved in the configuration 000÷064 for MASTER ; 000÷040 for MASTER-PC ; 000÷026 for MASTER-TRIO; 000÷064 for MASTER -TCP |
| 2 | Number of Online controller |
| 3 | Number of Offline controller |
| * 4 | * visible only on MASTER-TRIO It shows the total number of Trio units to be controlled (000÷048) |
| * 5 | * visible only on MASTER-TRIO It shows the number of Online Trio units |
| * 6 | * visible only on MASTER-TRIO It shows the total number of Offline Trio units |

| Table of movements | | |
|--------------------|--------|--|
| Key | Screen | |
| Esc | 1 | MENU |
| ↑ | 1.1.1 | GENERAL READINGS |
| ↓ | 1.1.3 | SLAVE UNIT READINGS (If in MASTER or MASTER-TRIO mode) |
| | 1.1.4 | GENERAL READINGS 1 |

N.B. In MASTER-PC mode data are not shown.

1.1.3 SLAVE UNIT READINGS SCREEN

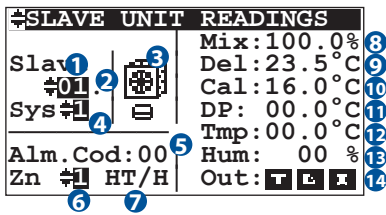

| Table of variables | |
|--------------------|---|
| Num | Description |
| 1 | Index of slave control units |
| 2 | . = Trio control units OFFLINE → = Trio control units ONLINE |
| 3 | Type of generator used in the selected system chiller; boiler Related activation status of production: ☑ Activated ; ☐ Deactivated |
| 4 | Index of the systems related to the selected slave unit |
| 5 | Alarm code for the selected zone/system |
| 6 | Index of the zone related to the selected system |
| 7 | Type of sensor used in the selected zone |
| 8 | Mixing valve opening percentage for the selected system If the mixing valve on the slave is ON |
| 9 | Delivery temperature detected in the selected system If the mixing valve on the slave is ON |
| 10 | Delivery temperature calculated in the selected system If the mixing valve on the slave is ON |
| 11 | Dew Point, it shows the temperature value for the dew point If configuration is in MASTER-TRIO mode |
| 12 | Room temperature detected on the SLAVE If the mixing valve on the slave is ON |
| 13 | Room humidity detected on the SLAVE If the mixing valve on the slave is ON |
| 14 | Zone output status T Temperature, L Humidity, I Integration If configuration is in MASTER-TRIO mode |

| Table of movements | | |
|--------------------|---------|---|
| Key | Screen | |
| Esc | 1 | MENU |
| Prg | 1.1.3.1 | SLAVE PROGRAMMING |
| ↑ | 1.1.2 | SLAVE GENERAL READINGS (In MASTER-PC mode data are not shown) |
| | 1.1.1 | GENERAL READINGS |
| ↓ | 1.1.4 | GENERAL READINGS 1 |

Please Note: This screen is only displayed in MASTER or MASTER-TRIO mode.



1.1.3.1 SLAVE PROGRAMMING SCREEN

| SLAVE PROGRAMMING | |
|-------------------|----------|
| 1 Slave ID: #01 | TrioType |
| STATUS | 00 |
| 2 General : | ON 0 0 |
| 3 System : #1 | ON 0 0 |
| 5 Zones : #1 | MAN 00.0 |
| 7 Confirm: No | 00.0 |

| Table of variables | |
|--|---|
| Num | Description |
| 1 | Index of slave control units |
| 2 | General status of the selected slave unit ON = Active OFF = Inactive |
| 3 | Index of the systems related to the selected slave unit |
| 4 | Status of the selected system ON = On OFF = Off |
| 5 | Index of the zone related to the selected system |
| 6 | Status of the selected zone OFF = Off MAN = Manual PGM = Programming PGM = Manual programming |
| 7 | Confirmation of data change |
| * Visible data only for MASTER-TRIO mode | |
| 8 * | Dew point |
| 9 * | Type TRIO (0 ÷ 5) |
| 10 * | On/off system 1 |
| 11 * | On/off system 2 |
| 12 * | Zone humidity |

| Table of movements | |
|--------------------|---------------------------|
| Key | Screen |
| Esc | 1.1.3 SLAVE UNIT READINGS |

Please Note: This screen is only displayed in MASTER or MASTER-TRIO mode.

1.1.4 GENERAL READINGS 1 SCREEN

| GENERAL READINGS 1 | |
|--------------------|-----------------|
| | DAYS HH MIN |
| 1 Time(S): | 00000 00 00 |
| 2 Time(W): | 00000 00 00 |
| 3 Sanitary (No) | |
| 4 T_SET: 55°C | + 05°C |
| 5 Temp: | 00.0°C |

| Table of variables | |
|--------------------|--|
| Num | Description |
| 1 | Operation time of primary production during the summer period |
| 2 | Operation time of primary production during the winter period |
| 3 | Indicates whether the sanitary system function is enabled |
| 4 | Set temperature for the sanitary system function (+ temperature delta compared to the set for deactivation the function) |
| 5 | Temperature detected by the delivery sensor on the sanitary system circuit |

| Table of movements | |
|--------------------|---|
| Key | Screen |
| Esc | 1 MENU |
| Up Arrow | 1.1.3 SLAVE UNIT READINGS (If in MASTER or MASTER-TRIO mode) |
| | 1.1.2 SLAVE GENERAL READINGS (In MASTER-PC mode data are not shown) |
| | 1.1.1 GENERAL READINGS |
| Down Arrow | 1.1.5 GENERAL READINGS 2 (if integration or alternating enabled) |
| | 1.1.6 SEASON READING |



1.1.5 GENERAL READINGS 2 SCREEN

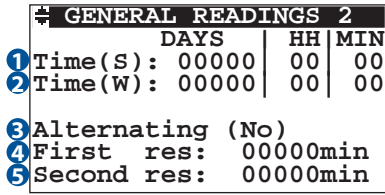

| Table of variables | |
|--------------------|---|
| Num | Description |
| 1 | Operation time of secondary production during the summer period |
| 2 | Operation time of secondary production during the winter period |
| 3 | Indicates whether the alternating function is enabled |
| 4 | Operation time of the primary source for the alternating function |
| 5 | Operation time of the secondary source for the alternating function |

| Table of movements | | |
|--------------------|--------|--------------------|
| Key | Screen | |
| Esc | 1 | MENU |
| ↑ | 1.1.4 | GENERAL READINGS 1 |
| ↓ | 1.1.6 | SEASON READING |

Please Note: This screen is only displayed if integration or alternating is enabled.

1.1.6 SEASON READING SCREEN



| Table of movements | | |
|--------------------|--------|--|
| Key | Screen | |
| Esc | 1 | MENU |
| ↑ | 1.1.5 | GENERAL READINGS 2 (if integration or alternating enabled) |
| | 1.1.4 | GENERAL READINGS 1 |
| ↓ | 1.1.7 | MAIN SYSTEM |

| Table of variables | |
|--------------------|---|
| Num | Description |
| 1 | Indicates which season the control unit is set to - Summer - Winter |

1.1.7 MAIN SYSTEM READING SCREEN

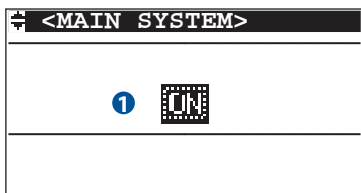

| Table of movements | | |
|--------------------|--------|------------------|
| Key | Screen | |
| Esc | 1 | MENU |
| ↑ | 1.1.6 | SEASON READING |
| ↓ | 1.1.1 | GENERAL READINGS |

| Table of variables | |
|--------------------|---|
| Num | Description |
| 1 | Indicates the general status of the master control unit - ON, the control unit operates according to standard logic - OFF, the control unit does not enable any digital output If there is a centralized MULTIMASTER - in the MASTER 1 control unit it indicates global On-Off - if the control units are MASTER ≠ 1, it indicates the On-Off of only the part related to the unit involved, |



1.2

TECHNICAL MENU SCREEN - PASSWORD

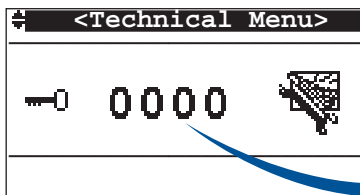

| Table of movements | | |
|--------------------|--------|----------------|
| Key | Screen | |
| | 1 | MENU |
| | 1.2.1 | TECHNICAL MENU |

To access the setting screens, enter the correct Password in the Technical Menu screen [9876].

Upon entering the correct password, you can proceed with the subsequent operations.

1.2.1

TECHNICAL MENU SCREEN

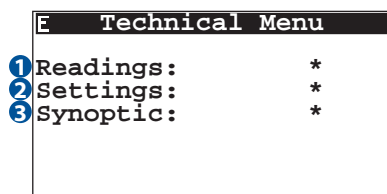

| Table of movements | | |
|--------------------|-----------|-------------------|
| Key | Screen | |
| | 0 | MAIN |
| | 1.2.1.1.1 | CENTRAL UNIT TYPE |
| + | 1.2.1.2 | SETTINGS |
| + + | 1.2.1.3.1 | SYNOPTIC RELAY |

| Table of variables | |
|--------------------|--|
| Num | Description |
| 1 | Access to the advanced readings screen |
| 2 | Access to the settings menu |
| 3 | Access to the synoptics screens |

1.2.1.1.1

CENTRAL UNIT TYPE SCREEN

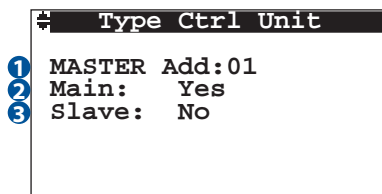

| Table of variables | |
|--------------------|--|
| Num | Description |
| 1 | Master unit address |
| 2 | Indicates if the unit is the master of the entire system (master add equal to 1) * |
| 3 | Indicates if the unit is master for a partial system and there is a main master (master add not 1) |

| Table of movements | | |
|--------------------|-----------|---|
| Key | Screen | |
| | 1.2.1 | TECHNICAL MENU |
| | 1.2.1.1.6 | MASTER-SLAVE READINGS |
| | 1.2.1.1.2 | SLAVE VALUE READINGS (if the master device is set to MASTER mode) |
| | 1.2.1.1.3 | SLAVE STATUS READINGS (if the master device is set to MASTER or MASTER-TRIO mode) |
| | 1.2.1.1.4 | RELAY 1-7 STATUS READINGS |

(* in the MASTER-PC type system, the master address **MUST** be 1



1.2.1.1.2 SLAVE VALUES SCREEN

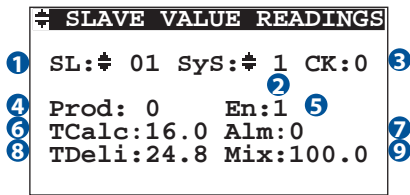

| Table of variables | |
|--------------------|---|
| Num | Description |
| 1 | Index of the queried slave |
| 2 | Index of the system related to the queried slave |
| 3 | Indicates if there is communication under way between the slave control unit and master |
| 4 | Production request from the system 0 - no request 1 - active request |
| 5 | Indicates the system status 0 - System OFF 1 - System ON |
| 6 | Delivery temperature calculated for the selected system |
| 7 | Alarms in the selected slave unit 0 - no alarm 1 - at least one alarm in progress |
| 8 | Delivery temperature detected in the selected system |
| 9 | Mixing valve opening percentage for the selected system |

| Table of movements | | |
|--------------------|-----------|---|
| Key | Screen | |
| | 1.2.1 | TECHNICAL MENU |
| | 1.2.1.1.1 | CENTRAL UNIT TYPE |
| | 1.2.1.1.3 | SLAVE STATUS READINGS (if the master device is set to MASTER or MASTER-TRIO mode) |
| | 1.2.1.1.4 | RELAY 1-7 STATUS READINGS |

Please Note: This screen is only displayed in MASTER mode.

1.2.1.1.3 SLAVE STATUS SCREEN

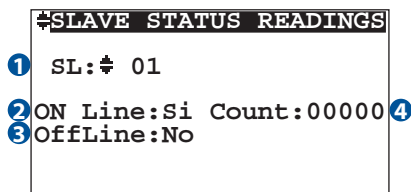

| Table of variables | |
|--------------------|---|
| Num | Description |
| 1 | Index of the queried slave |
| 2 / 3 | Indicates if the selected slave unit is in communication with the master unit |
| 4 | Indicates the number of zones online for the selected slave unit |

| Table of movements | | |
|--------------------|-----------|---|
| Key | Screen | |
| | 1.2.1 | TECHNICAL MENU |
| | 1.2.1.1.1 | CENTRAL UNIT TYPE |
| | 1.2.1.1.2 | SLAVE VALUE READINGS (if the master device is set to MASTER mode) |
| | 1.2.1.1.4 | RELAY 1-7 STATUS READINGS |

Please Note: This screen is only displayed in MASTER or MASTER-TRIO mode.



1.2.1.1.4 RELAY STATUS SCREEN

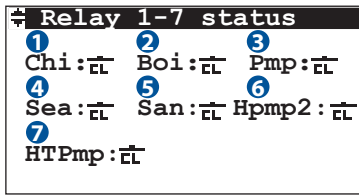

| Table of variables | |
|--------------------|-----------------------------------|
| Num | Description |
| 1 | Chiller relay / heat pump status |
| 2 | Boiler relay status |
| 3 | LT system pump relay status |
| 4 | Season relay status |
| 5 | Sanitary system relay status |
| 6 | Second energy source relay status |
| 7 | HT system pump relay status |

For all statuses they can be:
 = closed
 = open

| Table of movements | | |
|--------------------|-----------|---|
| Key | Screen | |
| | 1.2.1 | TECHNICAL MENU |
| | 1.2.1.1.1 | CENTRAL UNIT TYPE |
| | 1.2.1.1.2 | SLAVE VALUE READINGS (if the master device is set to MASTER mode) |
| | 1.2.1.1.3 | SLAVE STATUS READINGS (if the master device is set to MASTER or MASTER-TRIO mode) |
| | 1.2.1.1.5 | INPUT |

1.2.1.1.5 INPUT SCREEN

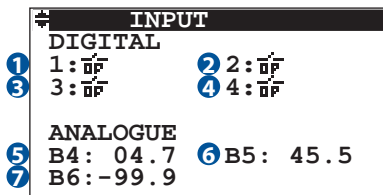

| Table of variables | |
|--------------------|------------------------------------|
| Num | Description |
| 1 | Digital input status (DI1) |
| 2 | Digital input status (DI2) |
| 3 | Digital input status (DI3) |
| 4 | Digital input status (DI4) |
| 5 | Analogue input value detected (B4) |
| 6 | Analogue input value detected (B5) |
| 7 | Analogue input value detected (B6) |

For all digital statuses they can be:
 = closed
 = open

| Table of movements | | |
|--------------------|-----------|---------------------------|
| Key | Screen | |
| | 1.2.1 | TECHNICAL MENU |
| | 1.2.1.1.4 | RELAY 1-7 STATUS READINGS |
| | 1.2.1.1.6 | MASTER-SLAVE READINGS |

1.2.1.1.6 MASTER-SLAVE READINGS SCREEN

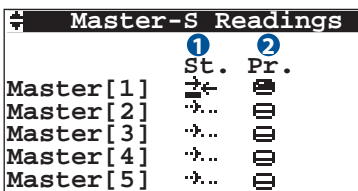

| Table of variables | |
|--------------------|---|
| Num | Description |
| 1 | Indicates the communication status between the various masters = communication present = no communication |
| 2 | Indicates the production request status for the various masters = production request active = no production request |

| Table of movements | | |
|--------------------|-----------|-------------------|
| Key | Screen | |
| | 1.2.1 | TECHNICAL MENU |
| | 1.2.1.1.5 | INPUT |
| | 1.2.1.1.1 | CENTRAL UNIT TYPE |



1.2.1.2 SETTINGS SCREEN

```

E <TM> SETTINGS
1 System      :      *
2 Season      :      *
3 Date Time   :      *
4 General     :      *
    
```

| Table of movements | | |
|--------------------|-------------|----------------|
| Key | Screen | |
| | 1.2.1 | TECHNICAL MENU |
| | 1.2.1.2.1 | MAIN SYSTEM |
| + | 1.2.1.2.2 | SEASON |
| + + | 1.2.1.2.3 | DATE-TIME |
| + + + | 1.2.1.2.4.1 | MASTER TYPE |

| Table of variables | |
|--------------------|--|
| Num | Description |
| 1 | Access to the screen to change the general system status |
| 2 | Access to the screen to change the season |
| 3 | Access to the screen to change the date/time |
| 4 | Access to the general settings screen |

1.2.1.2.1 MAIN SYSTEM SCREEN

```

E <MAIN SYSTEM>
ON 1
    
```

| Table of variables | |
|--------------------|--|
| Num | Description |
| 1 | Sets the general status of the master control unit - ON, the control unit operates according to standard logic - OFF, the control unit does not enable any digital output If there is a centralized MULTIMASTER - in the MASTER 1 control unit it sets the global On-Off - if the control units are MASTER ≠ 1, it only sets the On-Off of the part related to the unit involved, |

| Table of movements | | |
|--------------------|---------|----------|
| Key | Screen | |
| | 1.2.1.2 | SETTINGS |

1.2.1.2.2 SEASON SCREEN

```

E SEASON
1 Winter  ☀️ 🌧️
    
```

| Table of variables | |
|--------------------|------------------------|
| Num | Description |
| 1 | Settable system season |

| Table of movements | | |
|--------------------|---------|----------|
| Key | Screen | |
| | 1.2.1.2 | SETTINGS |

1.2.1.2.3 DATE-TIME SCREEN

```

E DATE TIME
      -hh-   -mm-
Fri      16 22
-dd--MM-   -YY-
11 July   2011
Summer time:Yes
    
```

| Table of variables | |
|--------------------|---|
| Num | Description |
| 1 | Hours |
| 2 | minutes |
| 3 | Day |
| 4 | Month |
| 5 | Year |
| 6 | Enables the automatic time change between standard time and daylight savings time |

| Table of movements | | |
|--------------------|---------|----------|
| Key | Screen | |
| | 1.2.1.2 | SETTINGS |



1.2.1.2.4.1 MASTER TYPE SCREEN

```

Master Type
1 Master Device:
  MASTER
2 Time OffLine:05min
    
```

| Table of variables | |
|--------------------|---|
| Num | Description |
| 1 | Type of master device: - MASTER the WI control unit is the master for the system - MASTER-PC the PC is the master for the system - MASTER-TRIO the WI control unit is the master for the system - MASTER-TCP the WI control unit is the master for the system |
| 2 | Delay time before defining the PC-MASTER offline |

| Table of movements | | |
|--------------------|--------------|--|
| Key | Screen | |
| Esc | 1.2.1.2 | SETTINGS |
| ↑ | 1.2.1.2.4.28 | LOAD DEFAULT |
| ↓ | 1.2.1.2.4.2 | SLAVE COMMUNICATION (If the master device is set to MASTER-PC or MASTER-TRIO mode) |
| | 1.2.1.2.4.3 | MAX SLAVE UNIT (If device is set to MASTER or MASTER-TRIO mode) |
| | 1.2.1.2.4.4 | S0 SUPERVISOR |

1.2.1.2.4.2 SLAVE COMMUNICATION SCREEN

```

SLAVE Communication
1 OffLine Rec. Time:60
2 Retry Number:3
3 Time Out S1:500 mSec
4 Time Alarm S1:120 Sec
    
```

| Table of variables | |
|--------------------|---|
| Num | Description |
| 1 | Delay time before rechecking the connection |
| 2 | Number of attempts before indicating an offline error |
| 3 | Delay time between attempts |
| 4 | Delay time before activating the offline alarm |

| Table of movements | | |
|--------------------|-------------|---|
| Key | Screen | |
| Esc | 1.2.1.2 | SETTINGS |
| ↑ | 1.2.1.2.4.1 | MASTER TYPE |
| ↓ | 1.2.1.2.4.3 | MAX SLAVE UNIT (If device is set to MASTER or MASTER-TRIO mode) |
| | 1.2.1.2.4.4 | S0 SUPERVISOR |

Please Note: This screen is only displayed in MASTER or MASTER-TRIO mode.

1.2.1.2.4.3 MAX SLAVE UNIT SCREEN

```

Max Unit SLAVE
1 MaxUnitId:001

SLAVE CONFIGURATION
>>>>>>>>>>>>
Press Prg
    
```

| Table of variables | |
|--------------------|--|
| Num | Description |
| 1 | Maximum index of connected slaves: 64 for MASTER and MASTER-TCP systems 40 for MASTER-PC systems 26 for MASTER-TRIO systems |

| Table of movements | | |
|--------------------|---------------|--|
| Key | Screen | |
| Esc | 1.2.1.2 | SETTINGS |
| ↑ | 1.2.1.2.4.1 | MASTER TYPE |
| | 1.2.1.2.4.2 | SLAVE COMMUNICATION (If the master device is set to MASTER-PC or MASTER-TRIO mode) |
| Prg | 1.2.1.2.4.3.1 | UNIT CONFIGURATION |
| ↓ | 1.2.1.2.4.4 | S0 SUPERVISOR |

Please Note: This screen is only displayed in MASTER or MASTER-TRIO mode.



ADDRESS 1 MENU / 1.2 TECHNICAL MENU - PASSWORD / 1.2.1 TECHNICAL MENU / 1.2.1.2 SETTINGS / 1.2.1.2.4 GENERAL
1.2.1.2.4.3 MAX SLAVE UNITS

1.2.1.2.4.3.1 UNIT CONFIGURATION SCREEN

MASTER or MASTER-PC

```

⇄ CONFIGURATION
UNIT:001 ①
PRESENT: YES ②
  
```

MASTER-TRIO

```

⇄ CONFIGURATION
UNIT:001 ①
001
1° Zone PRESENT: Yes
③ 002
2° Zone PRESENT: No
  
```

Table of variables

| Num | Description |
|-----|--|
| ① | ID Slave (MaxUnitID) |
| ② | Sets the presence of the slave with the selected ID |
| ③ | (only for MASTER-TRIO) Set the presence of TRIO controller in the zones |

Table of movements

| Key | Screen |
|-----|----------------------------|
| Esc | 1.2.1.2.4.3 MAX SLAVE UNIT |

ADDRESS 1 MENU / 1.2 TECHNICAL MENU - PASSWORD / 1.2.1 TECHNICAL MENU / 1.2.1.2 SETTINGS / 1.2.1.2.4 GENERAL

1.2.1.2.4.4 S0 SUPERVISOR SCREEN

```

⇄ S0 SUPERVISOR
Plan [Port 0]
① ID Number: 001
② Speed: 19200
③ Prot: 5:pLAN
④ Port: 2 ⑤ CP->05
  
```

Table of movements

| Key | Screen |
|-----|--|
| Esc | 1.2.1.2 SETTINGS |
| ↑ | 1.2.1.2.4.1 MASTERTYPE 1.2.1.2.4.2 SLAVE COMMUNICATION (If the master device is set to MASTER-PC or MASTER-TRIO mode) |
| | 1.2.1.2.4.3 MAX SLAVE UNIT (If device is set to MASTER or MASTER-TRIO mode) |
| ↓ | 1.2.1.2.4.5 S1 SUPERVISOR |

Table of variables

| Num | Description |
|-----|---------------------------------|
| ① | Master control unit ID |
| ② | Transmission speed |
| ③ | Transmission protocol |
| ④ | Communication port |
| ⑤ | Communication protocol code set |

ADDRESS 1 MENU / 1.2 TECHNICAL MENU - PASSWORD / 1.2.1 TECHNICAL MENU / 1.2.1.2 SETTINGS / 1.2.1.2.4 GENERAL

1.2.1.2.4.5 S1 SUPERVISOR SCREEN

MASTER-PC

```

⇄ S1 SUPERVISOR
BMS [Port 1]
① BMS Address: 001
② Speed: 19200
③ Prot: CarelMaster
④ Port: 4
⑤ BMS Prot: 1
  
```

```

⇄ S1 SUPERVISOR
BMS [Port 1]
① BMS Address: 001
② Speed: 38400
③ Prot: ModBusExt SL(30)
④ Port: 2
⑤ BMS Prot: 30
  
```

```

⇄ S1 SUPERVISOR
BMS [Port 1]
① BMS Address: 001
② Speed: 19200
③ Prot: ModBusExt SL(30)
④ Port: 2
⑤ BMS Prot: 30
  
```

Table of movements

| Key | Screen |
|-----|---------------------------|
| Esc | 1.2.1.2 SETTINGS |
| ↑ | 1.2.1.2.4.4 S0 SUPERVISOR |
| ↓ | 1.2.1.2.4.6 S2 SUPERVISOR |

Table of variables

| Num | Description |
|-----|---------------------------------------|
| ① | Device communication address |
| ② | Transmission speed |
| ③ | Transmission protocol |
| ④ | Communication port |
| ⑤ | Type of protocol set on S1 supervisor |



1.2.1.2.4.6 S2 SUPERVISOR SCREEN

```

S2 SUPERVISOR
FIELD-BUS [PORT 2]
1 F.B. Address:001
2 Speed:19200
3 Prot.:1:mast. 485-(18)
4 F.B. Prot.:18
    
```

| Table of movements | | |
|--------------------|-------------|--|
| Key | Screen | |
| | 1.2.1.2 | SETTINGS |
| | 1.2.1.2.4.5 | S1 SUPERVISOR |
| | 1.2.1.2.4.7 | PRODUCTION FORCE (If in MASTER-PC mode and with the PC offline.) |
| | 1.2.1.2.4.8 | TIMER START STOP |

| Table of variables | |
|--------------------|---------------------------------------|
| Num | Description |
| 1 | Device communication address |
| 2 | Transmission speed |
| 3 | Transmission protocol |
| 4 | Type of protocol set on S2 supervisor |

1.2.1.2.4.7 PRODUCTION FORCE

```

Production Force
1 Production:OFF
2 Deliver temp.:15.0°C
    
```

| Table of variables | |
|--------------------|--|
| Num | Description |
| 1 | Activates or deactivates the forced production of energy |
| 2 | Sets delivery temperature for forced production |

| Table of movements | | |
|--------------------|-------------|------------------|
| Key | Screen | |
| | 1.2.1.2 | SETTINGS |
| | 1.2.1.2.4.6 | S2 SUPERVISOR |
| | 1.2.1.2.4.8 | TIMER START STOP |

Please Note: This screen is only displayed in PC master mode and with the PC offline.

1.2.1.2.4.8 TIMER START STOP SCREEN

```

Timer Start Stop
          Start      Stop.
1 PROD : 010sec |
2 PUMP : 045sec | 180sec 3
    
```

| Table of movements | | |
|--------------------|-------------|--|
| Key | Screen | |
| | 1.2.1.2 | SETTINGS |
| | 1.2.1.2.4.7 | PRODUCTION FORCE (If in MASTER-PC mode and with the PC offline.) |
| | 1.2.1.2.4.6 | S2 SUPERVISOR |
| | 1.2.1.2.4.9 | PRODUCTION TYPE |

| Table of variables | |
|--------------------|---|
| Num | Description |
| 1 | Delay before activating energy production |
| 2 | Daly before activating the system pump |
| 3 | Daly before turning off the system pump |



1.2.1.2.4.9 PRODUCTION TYPE

```

PRODUCTION TYPE
1 TYPE:Chiller+Boiler
2 En Switch Prd2:No
3 TempExt.Switch:05.0 °C
4 DelaySwitchPrd2:030sec
Prd1=Consent NO1
Prd2=Consent NO2
    
```

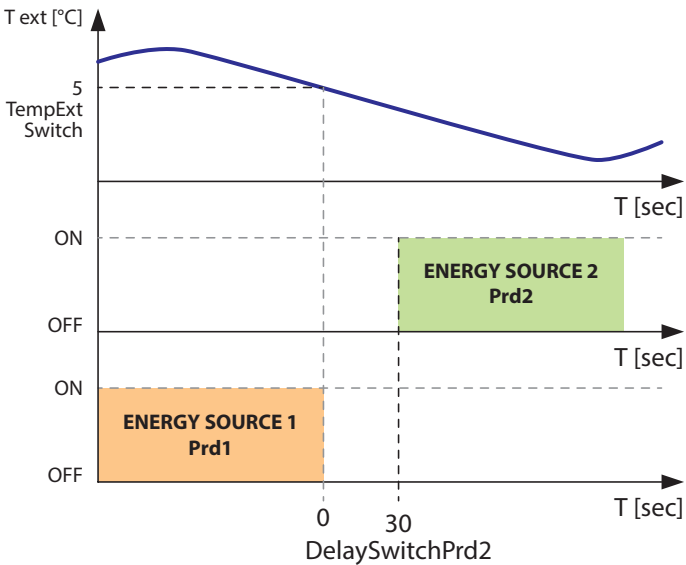

| Table of variables | |
|--------------------|---|
| Num | Description |
| 1 | Type of energy production: - Chiller + Boiler - Heat pump |
| 2 | Enables energy source change (from heat pump to boiler) |
| 3 | Outdoor temperature set point below which the energy source change is enabled |
| 4 | Delay before activating energy source change |

| Table of movements | | |
|--------------------|--------------|---|
| Key | Screen | |
| Esc | 1.2.1.2 | SETTINGS |
| ↑ | 1.2.1.2.4.8 | TIMER START STOP |
| ↓ | 1.2.1.2.4.10 | PRODUCTION X TCalc (if TYPE = Chiller+Caldaia and DelaySwitchPrd2 = No) |
| | 1.2.1.2.4.11 | SANITARY FUNCTION |

1.2.1.2.4.10 PRODUCTION X TCalc

```

PRODUCTION X TCalc
1 Enable : No
2 Win:Prd1<40.0 °C>Prd2
3 Sum:Prd2<15.0 °C>Prd1
4 Hysteresis: 1.0
Prd1=Consent NO1
Prd2=Consent NO2
    
```

| Table of movements | | |
|--------------------|--------------|-------------------|
| Key | Screen | |
| Esc | 1.2.1.2 | SETTINGS |
| ↑ | 1.2.1.2.4.9 | PRODUCTION TYPE |
| ↓ | 1.2.1.2.4.11 | SANITARY FUNCTION |

| Table of variables | |
|--------------------|---|
| Num | Description |
| 1 | Switch energy source according to the calculated supply temperature |
| 2 | Winter temperature set calculated for energy source switch |
| 3 | Summer temperature set calculated for energy source switch |
| 4 | Hysteresis on the set valuer for energy source switch |

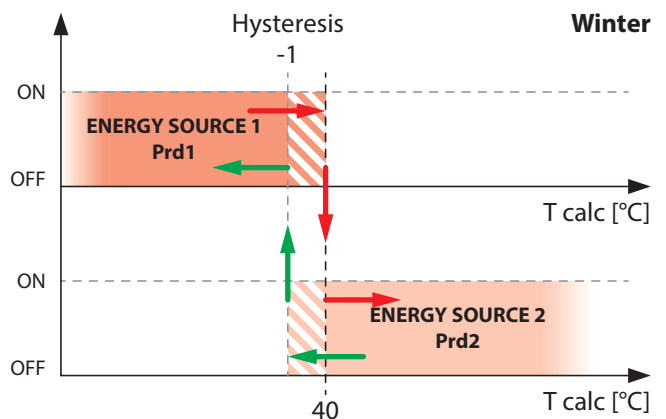
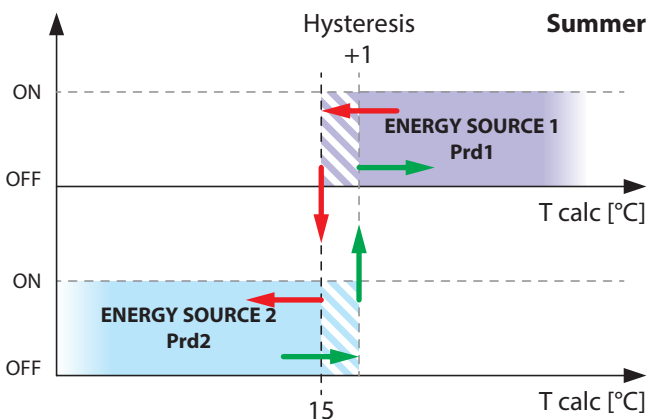



1.2.1.2.4.11 SANITARY SYSTEM FUNCTION SCREEN

| ←FUNC. SANITARY SYSTEM | |
|------------------------|---------------------|
| 1 | Enable: Yes |
| 2 | T_SET: 55°C |
| 3 | Delta_T: 05°C |
| 4 | SEL: PROD_SUM: PDC2 |
| 5 | SEL: PROD_WIN: PDC2 |

| Table of movements | | |
|--------------------|--------------|--|
| Key | Screen | |
| Esc | 1.2.1.2 | SETTINGS |
| ↑ | 1.2.1.2.4.10 | PRODUCTION X T CALC (if TYPE = Chiller+Caldaia and DelaySwitchPrd2 = No) |
| | 1.2.1.2.4.9 | PRODUCTION TYPE |
| ↓ | 1.2.1.2.4.12 | INTEGRATION FUNCTION |

| Table of variables | |
|--------------------|--|
| Num | Description |
| 1 | Enables sanitary system function |
| 2 | Set sanitary system temperature for production activation |
| 3 | Delta of temperature from the set point for production deactivation |
| 4 | Selects the energy source to start domestic water function in summer |
| 5 | Selects the energy source to start domestic water function in winter |

This function allows the activation of an output on the master control unit (DO4) to activate a possible heat source (secondary boiler, electrical resistance, etc.). The output is enabled if:

- the function is enabled
- the accumulation temperature (read from the temperature sensor connected to the B4 analogue input) is less than the value set in the parameter T_SET
- there is an external request from a remote digital input (settable from the user interface)

The graph below shows the type of sanitary system function.

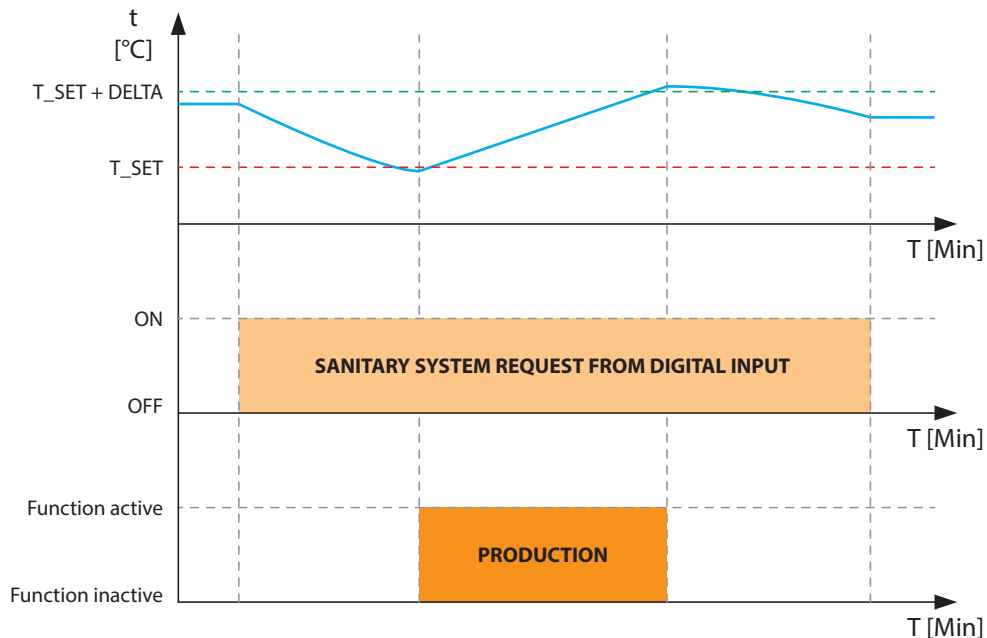

The parameters SEL_PROD_EST and SEL_PROD_INV control which type of energy sources can be selected and activated for the domestic water in summer and winter. Five different options are available:

1. N.U. (Not used),
2. Chiller/PDC1 (heat pump1) for N01 output,
3. Boiler for N02 output,
4. Prod (Production) for N01 output in case PDC (heat pump) is enabled with or without enabling production change when outdoor temperature is higher then the change set value. In case of lower temperature than the change set value, N02 output will be activated
5. PDC2 (heat pump2) for N05 output.



1.2.1.2.4.12 INTEGRATION FUNCTION SCREEN

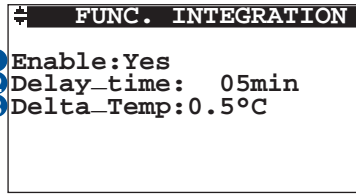

| Table of movements | |
|--------------------|--------------------------------|
| Key | Screen |
| | 1.2.1.2 SETTINGS |
| | 1.2.1.2.4.11 SANITARY FUNCTION |
| | 1.2.1.2.4.13 ALTERNATING |

| Table of variables | |
|--------------------|--|
| Num | Description |
| 1 | Enables integration function |
| 2 | Delay time before starting production from the second energy source |
| 3 | Temperature delta between the temperature detected and the set point for which the integration function is activated |

This function allows a second heat pump to be activated if the first one does not satisfy the energy needs during the set period. The output is enabled if:

- the function is enabled
- the temperature detected does not reach at least the set threshold for the set temperature within a certain time period

Please Note: When the production request is activated, the system waits 5 minutes before performing the temperature check, after which, if conditions require energy from the second source, the countdown starts for the delay time set by the user. If after this further delay the temperature detected has not reached the range between the threshold delta and the set point, production is activated from the second energy source.

The graph below shows the type of integration function in the winter season.

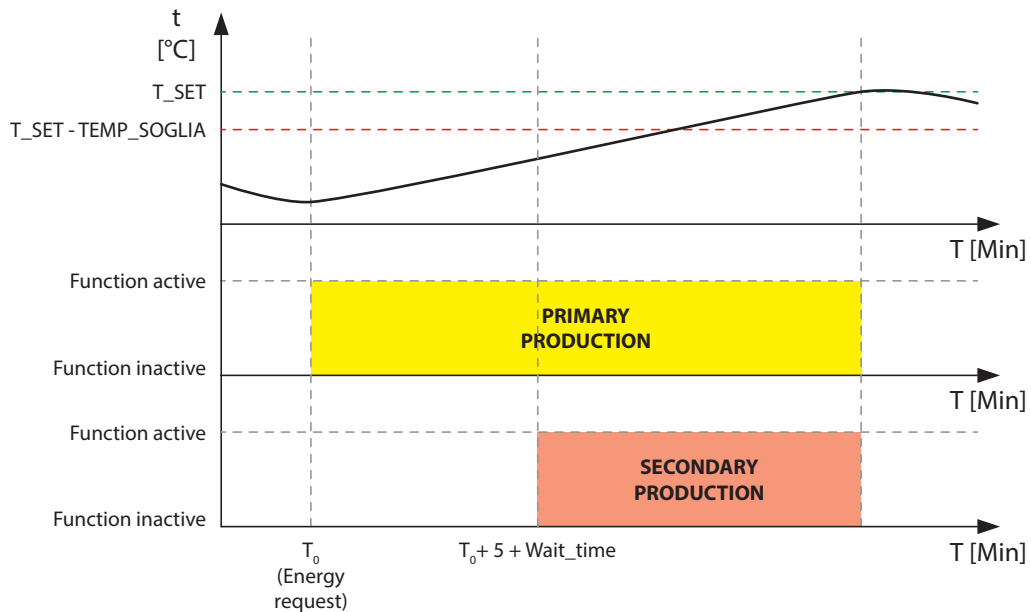



1.2.1.2.4.13 ALTERNATING FUNCTION SCREEN

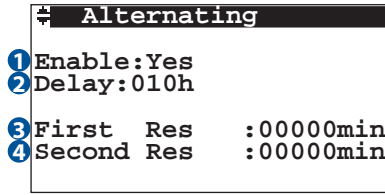

| Table of movements | | |
|--------------------|--------------|--------------------------|
| Key | Screen | |
| Esc | 1.2.1.2 | SETTINGS |
| ↑ | 1.2.1.2.4.12 | INTEGRATION FUNCTION |
| ↓ | 1.2.1.2.4.14 | MASTER.NET CONFIGURATION |

| Table of variables | |
|--------------------|--|
| Num | Description |
| 1 | Enable alternating |
| 2 | Delay time for performing the energy source change |
| 3 | Operating time of the first source from the last change |
| 4 | Operating time of the second source from the last change |

This function can only be used when there are 2 equal machines (2 chillers, 2 boilers or 2 heat pumps) that supply energy to the system. The objective is to alternate use of the machines during their operating period so that the wear is the same for both.

This usage "exchange" is activated if:

- the function is enabled
- The difference between the usage time of one machine and the usage time of another is greater than the "Timer delay" parameter.

EXAMPLE:

- 2 heat pumps
- Delay timer = 5 hours
- First res. = 20 hours (H_{HP1})
- Second res. = 20 hours (H_{HP2})

In this condition, at the first production request, Heat Pump "1" will be activated. Assuming that it runs for 6 hours we find:

- First res. = 26 hours
- Second res. = 20 hours

At the next energy request, Heat Pump "2" is activated since $|H_{HP1} - H_{HP2}| > 5$ or the "Timer delay" set point

Let's then assume that the second energy source operates for 4 hours and we find:

- First res. = 26 hours
- Second res. = 24 hours

At the next energy request, Heat Pump "2" is activated again since $|H_{HP1} - H_{HP2}| < 5$

The graph below shows an example of this

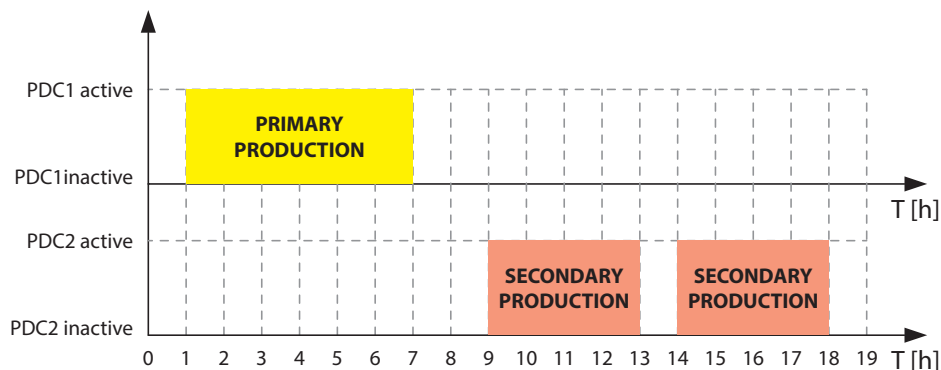



1.2.1.2.4.14 MASTER.NET DI CONFIGURATION SCREEN

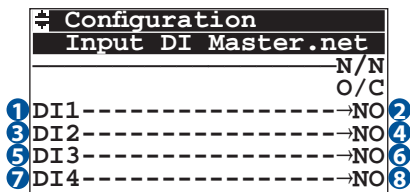

| Table of movements | | |
|--------------------|--------------|----------------|
| Key | Screen | |
| | 1.2.1.2 | SETTINGS |
| | 1.2.1.2.4.13 | ALTERNATING |
| | 1.2.1.2.4.15 | ALARM SETTINGS |

| Table of variables | |
|--------------------|---------------------------|
| Num | Description |
| 1 | Digital input type on DI1 |
| 2 | DI1 Configuration |
| 3 | Digital input type on DI2 |
| 4 | DI2 Configuration |
| 5 | Digital input type on DI3 |
| 6 | DI3 Configuration |
| 7 | Digital input type on DI4 |
| 8 | DI4 Configuration |

All of the digital inputs can be set with the following functions:

- Boiler alarm
- Chiller alarm
- Sanitary System
- Remote LT input
- Remote HT input
- General On-Off
- Season

And can be defined as:

- NO - Contact normally open
- NC - Contact normally closed

1.2.1.2.4.15 ALARM SETTING SCREEN

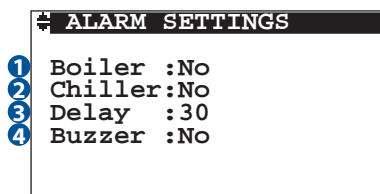

| Table of movements | | |
|--------------------|--------------|----------------------|
| Key | Screen | |
| | 1.2.1.2 | SETTINGS |
| | 1.2.1.2.4.14 | MASTER CONFIGURATION |
| | 1.2.1.2.4.16 | TIMER |

| Table of variables | |
|--------------------|--|
| Num | Description |
| 1 | Indicates if the boiler alarm was enabled |
| 2 | Indicates if the chiller alarm was enabled |
| 3 | Delay time before the first alarm is set off |
| 4 | Enables the buzzer in the event of an alarm |

1.2.1.2.4.16 TIMER SCREEN

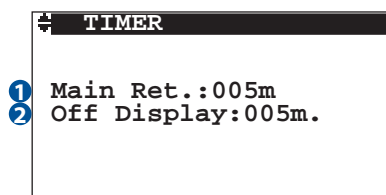

| Table of variables | |
|--------------------|--|
| Num | Description |
| 1 | Time of non-use of the user interface for automatic return to the main screen |
| 2 | Time of non-use of the user interface for automatic shut-off of the backlighting |

| Table of movements | | |
|--------------------|--------------|--|
| Key | Screen | |
| | 1.2.1.2 | SETTINGS |
| | 1.2.1.2.4.15 | ALARM SETTINGS |
| | 1.2.1.2.4.17 | DELIVERY CALCUL. TYPE (If in MASTER or MASTER-TRIO mode) |
| | 1.2.1.2.4.18 | WINTER COMPENSATION |



1.2.1.2.4.17 DELIVERY CALCULATION TYPE SCREEN

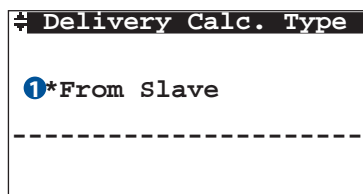

| Table of variables | |
|--------------------|--|
| Num | Description |
| 1 | Calculation typer for supply water temperature: - FROM SLAVE, the temperatura calculated by the master unit depends on the temperature calculated by the slave unit - OUT.TMP.COMP., the temperatura calculated by the master unit depends on the climatic curve |

Please Note: This screen is only displayed in MASTER or MASTER-TRIO mode.

| Table of movements | | |
|--------------------|--------------|---------------------|
| Key | Screen | |
| Esc | 1.2.1.2 | SETTINGS |
| ↑ | 1.2.1.2.4.16 | TIMER |
| ↓ | 1.2.1.2.4.18 | WINTER COMPENSATION |

1.2.1.2.4.18 WINTER COMPENSATION SCREEN

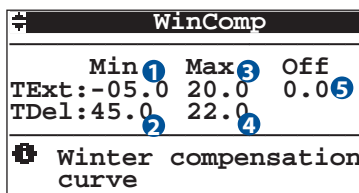

| Table of movements | | |
|--------------------|--------------|--|
| Key | Screen | |
| Esc | 1.2.1.2 | SETTINGS |
| ↑ | 1.2.1.2.4.17 | DELIVERY CALCUL. TYPE (If in MASTER or MASTER-TRIO mode) |
| | 1.2.1.2.4.16 | TIMER |
| ↓ | 1.2.1.2.4.19 | SUMMER COMPENSATION |

| Table of variables | |
|---------------------------------------|--|
| Num | Description |
| Change the winter compensation curve: | |
| 1 | TExt –Min: Min. Outdoor temperature |
| 2 | TDel –Min: Min. Supply Water temperature |
| 3 | TExt –Max: Max. Outdoor temperature |
| 4 | TDel–Max: Max Supply Water temperature |
| 5 | Off: Offset (parallel shift for the compensation curve). |

1.2.1.2.4.19 SUMMER COMPENSATION SCREEN

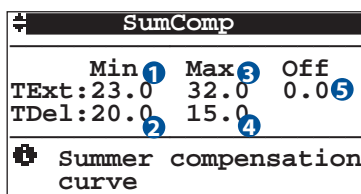

| Table of variables | |
|---------------------------------------|--|
| Num | Description |
| Change the summer compensation curve: | |
| 1 | TExt –Min: Min. Outdoor temperature |
| 2 | TDel –Min: Min. Supply Water temperature |
| 3 | TExt –Max: Max. Outdoor temperature |
| 4 | TDel–Max: Max Supply Water temperature |
| 5 | Off: Offset (parallel shift for the compensation curve). |

| Table of movements | | |
|--------------------|--------------|--|
| Key | Screen | |
| Esc | 1.2.1.2 | SETTINGS |
| ↓ | 1.2.1.2.4.18 | WINTER COMPENSATION |
| | 1.2.1.2.4.20 | DELIVERY TEMPERATURE (If there is a delivery sensor) |
| | 1.2.1.2.4.22 | M-SLAVE COMMUNICATION (Only if in MULTI-MASTER mode) |
| | 1.2.1.2.4.23 | PASSWORD |



1.2.1.2.4.20 DELIVERY TEMPERATURE SCREEN

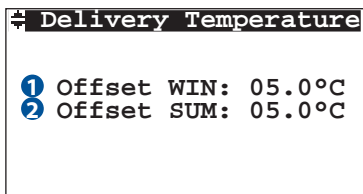

| Table of movements | | |
|--------------------|--------------|---------------------|
| Key | Screen | |
| | 1.2.1.2 | SETTINGS |
| | 1.2.1.2.4.19 | SUMMER COMPENSATION |
| | 1.2.1.2.4.21 | SET MIX MASTER |

Please Note: This screen is only displayed if there is a delivery sensor

| Table of variables | |
|--------------------|---|
| Num | Description |
| 1 | Delivery temperature offset from the maximum requested between all the slave units in the winter season |
| 2 | Delivery temperature offset from the minimum requested between all the slave units in the summer season |

1.2.1.2.4.21 SET MIX MASTER SCREEN

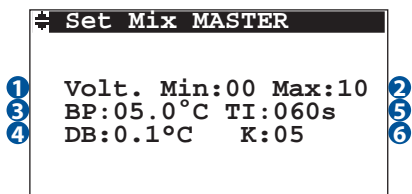

| Table of variables | |
|--------------------|--|
| Num | Description |
| 1 | Minimum voltage to supply to the servomotor |
| 2 | Maximum voltage to supply to the servomotor |
| 3 | (min 2°C- max 10°C) Proportional band in °C. This value represents the interval within which the mixing valve intervenes by means of a PID logic. Outside of the PB, the mixing valve performs an action equal to 20% of the voltage from signal 0-10. |
| 4 | (min 0°C- max 2°C) dead band in °C (band where the mixing valve performs no action). |
| 5 | (min 10sec -max500 sec) Integral Time (PID calculation integration time). |
| 6 | (min 0- max 10) Approach speed towards the calculated temperature. |

| Table of movements | | |
|--------------------|--------------|--|
| Key | Screen | |
| | 1.2.1.2 | SETTINGS |
| | 1.2.1.2.4.20 | DELIVERY TEMPERATURE |
| | 1.2.1.2.4.22 | M-SLAVE COMMUNICATION (Only if in MULTI-MASTER mode) |
| | 1.2.1.2.4.23 | PASSWORD |

Please Note: This screen is only displayed if there is a delivery sensor

1.2.1.2.4.22 M-SLAVE COMMUNICATION SCREEN

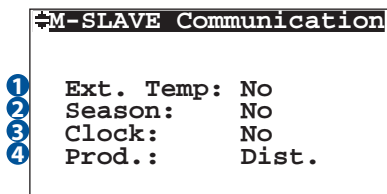

| Table of variables | |
|--------------------|--|
| Num | Description |
| 1 | Sets the outdoor temperature reading from the sensor on the primary master unit. |
| 2 | Sets the season from the set point on the primary master unit. |
| 3 | Sets the clock on the primary master unit as reference for the secondary master |
| 4 | Sets the production type Dist = Each master unit manages its own production Cent = Production is managed only by the primary master control unit |

Please Note: This screen is only displayed in MULTI-MASTER mode.

| Table of movements | | |
|--------------------|--------------|--|
| Key | Screen | |
| | 1.2.1.2 | SETTINGS |
| | 1.2.1.2.4.19 | SUMMER COMPENSATION |
| | 1.2.1.2.4.21 | SET MIX MASTER (If there is a delivery sensor) |
| | 1.2.1.2.4.23 | PASSWORD |



1.2.1.2.4.23 PASSWORD SCREEN

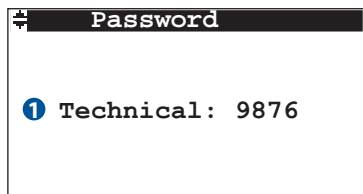

| Table of movements | | |
|--------------------|--------------|--|
| Key | Screen | |
| | 1.2.1.2 | SETTINGS |
| | 1.2.1.2.4.22 | M-SLAVE COMMUNICATION (Only if in MULTI-MASTER mode) |
| | 1.2.1.2.4.21 | SET MIX MASTER (If there is a delivery sensor) |
| | 1.2.1.2.4.19 | SUMMER COMPENSATION |
| | 1.2.1.2.4.24 | AUTOCONFIGURATION WIZARD (visible if the master type is set on MASTER) |
| | 1.2.1.2.4.25 | LANGUAGE |

| Table of variables | |
|--------------------|--|
| Num | Description |
| 1 | Sets the password to access the technical menu |

1.2.1.2.4.24 AUTOCONFIGURATION WIZARD SCREEN

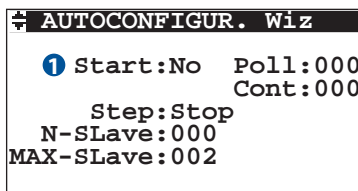

| Table of movements | | |
|--------------------|--------------|----------|
| Key | Screen | |
| | 1.2.1.2 | SETTINGS |
| | 1.2.1.2.4.23 | PASSWORD |
| | 1.2.1.2.4.25 | LANGUAGE |

| Table of variables | |
|--------------------|--|
| Num | Description |
| 1 | Activates the automatic research of the slave control unit connected to the master |

Please Note: This screen is only displayed in MASTER mode.

1.2.1.2.4.25 LANGUAGE SCREEN



| Table of movements | | |
|--------------------|--------------|--|
| Key | Screen | |
| | 1.2.1.2 | SETTINGS |
| | 1.2.1.2.4.24 | AUTOCONFIGURATION WIZARD (visible if the master type is set on MASTER) |
| | 1.2.1.2.4.23 | PASSWORD |
| | 1.2.1.2.4.26 | RESET ALARMS |

| Table of variables | |
|--------------------|--------------------------------|
| Num | Description |
| 1 | Sets the control unit language |



1.2.1.2.4.26 RESET ALARMS SCREEN



| Table of movements | | |
|--------------------|--------------|-------------|
| Key | Screen | |
| | 1.2.1.2 | SETTINGS |
| | 1.2.1.2.4.25 | LANGUAGE |
| | 1.2.1.2.4.27 | RESET TIMER |

| Table of variables | |
|--------------------|---|
| Num | Description |
| 1 | Resets the alarms on all of the slave units |
| 2 | Resets the alarms on the master unit |

1.2.1.2.4.27 RESET TIMER SCREEN

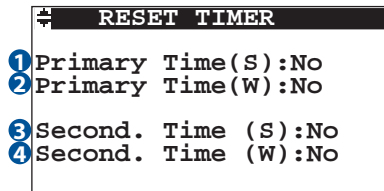

| Table of movements | | |
|--------------------|--------------|--------------|
| Key | Screen | |
| | 1.2.1.2 | SETTINGS |
| | 1.2.1.2.4.26 | RESET ALARMS |
| | 1.2.1.2.4.28 | DEFAULT LOAD |

| Table of variables | |
|--------------------|---|
| Num | Description |
| 1 | Resets the primary source timer in summer operation |
| 2 | Resets the primary source timer in winter operation |
| 3 | Resets the secondary source timer in summer operation |
| 4 | Resets the secondary source timer in winter operation |

1.2.1.2.4.28 DEFAULT LOAD SCREEN

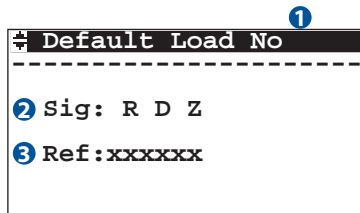

| Table of variables | |
|--------------------|---|
| Num | Description |
| 1 | Activates the loading of the default data |
| 2 | Manufacturer Name |
| 3 | Control unit reference order |

| Table of movements | | |
|--------------------|--------------|-------------|
| Key | Screen | |
| | 1.2.1.2 | SETTINGS |
| | 1.2.1.2.4.27 | RESET TIMER |
| | 1.2.1.2.4.1 | MASTER TYPE |



1.2.1.3.1 SYNOPTICS RELAY SCREEN

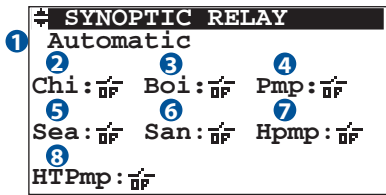

| Table of variables | |
|--------------------|--|
| Num | Description |
| 1 | Enables or disables synoptics management by the user |
| 2 | Chiller relay |
| 3 | Boiler relay |
| 4 | System pump relay |
| 5 | Season relay |
| 6 | Sanitary relay |
| 7 | Secondary heat source relay |
| 8 | High temperature pump relay |

| Table of movements | | |
|--------------------|-----------|----------------|
| Key | Screen | |
| Esc | 1.2.1 | TECHNICAL MENU |
| Up / Down | 1.2.1.3.2 | GENERAL MIX |

1.2.1.3.2 GENERAL MIX SCREEN

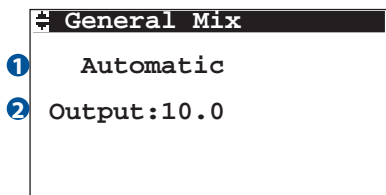

| Table of variables | |
|--------------------|--|
| Num | Description |
| 1 | Enables or disables synoptics management by the user |
| 2 | Analogue output voltage 0-10 |

| Table of movements | | |
|--------------------|-----------|----------------|
| Key | Screen | |
| Esc | 1.2.1 | TECHNICAL MENU |
| Up / Down | 1.2.1.3.1 | SYNOPTIC RELAY |

TROUBLESHOOTING

The red backlight on the "Alarm" button indicates that the control unit has detected a system failure or malfunction. To display them, press the "Alarm" button: once pressed, the screen will display all the information regarding the error. In the event of several errors, you can scroll through them using the UP-DOWN buttons. To return to the control unit menu, press the "Alarm" button again.

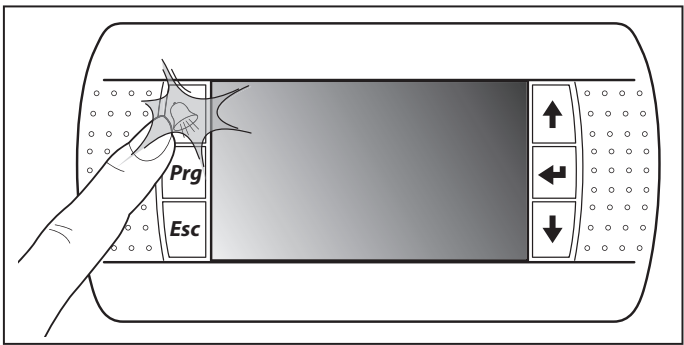

The following page lists the possible alarms:

PLEASE NOTE: If the problem is resolved, the error will no longer be displayed when you access the alarm screens again. If everything in the control unit is working properly and you press the "Alarm" button, the screen indicating that there is no ongoing alarm will appear.



Table F - Alarms

1) OUTDOOR SENSOR ALARM

ALARM

OUTDOOR TEMPERATURE 

The outdoor temperature sensor is faulty or disconnected
PLEASE NOTE: the system will continue to function, simulating an outdoor temperature of 5°C during the winter and 30 °C during the summer.

2) CHILLER / HEAT PUMP ALARM:

 CHILLER ALARM
OR
HEAT PUMP ALARM

Chiller / Heat pump lock (Summer season).
All the systems are disabled.

3) BOILER / HEAT PUMP ALARM

 BOILER ALARM
OR
HEAT PUMP ALARM

Boiler / Heat pump lock (Winter season).
All the systems are disabled.

4) SLAVE OFFLINE ALARM



ALARM

SLAVE OFF LINE 
>>>>>>
Press Enter

| SLAVE OFF LINE | | | | | | | | |
|----------------|---|---|---|-------|---|---|---|---|
| From 001 | | | | A 016 | | | | |
| 01 | 1 | 2 | 3 | 4 | 5 | 6 | 7 | 8 |
| --- |  | . | . | . | . | . | . | . |
| 0000 | . | . | . | . | . | . | . | . |

MASTER or MASTER-PC

This screen displays the status of the slave control unit in comparison to the master:



-  = Online
-  = Offline
- . = Not present / not configured

This screen shows that at least one slave control unit is offline (is no longer communicating with the master)

| SLAVE OFF LINE | | | | | | | | |
|----------------|---|---|---|-------|---|---|---|---|
| From 001 | | | | A 016 | | | | |
| 01 | 1 | 2 | 3 | 4 | 5 | 6 | 7 | 8 |
| --- |  | . | . | . | . | . | . | . |
| 0000 | . | . | . | . | . | . | . | . |

MASTER-TRIO



This screen displays the status of the slave control unit in comparison to the master:

-  = Online
-  = Offline
- . = Not present / not configured

5) SYSTEM OFFLINE ALARM

ALARM

SYSTEM 
>>>>>>
Press Enter

| SYSTEM ALARM | | | | | | | | |
|---------------|---|---|---|---|---|---|---|---|
| Slave IDX:000 | | | | 0000 | | | | |
| System List | | | | | | | | |
| | 1 | 2 | 3 | 4 | 5 | 6 | 7 | 8 |
| |  | - | - |  | - | - | - | - |

The left screen shows that at least one system is alarming (faulty delivery sensor)

The right screen shows which system of the selected slave is faulty.

 = System is in alarm status

6) SANITARY DELIVERY SENSOR ALARM

ALARM

SENSOR ALARM 
DELIVERY - SANITARY
TEMPERATURE

Indicates that the sanitary delivery temperature sensor is faulty or disconnected

7) PC OFFLINE ALARM

OFFLINE ALARM

PC - OFF LINE 

Indicates that the PC (MASTER-PC mode) is offline in relation to the master control unit



DATA TABLES

DEFAULT VALUES

GENERAL CT

| NAME | Description | Value | U.M. |
|--------------------|---|-------|------|
| Main System | General: If OFF, no function is activated | OFF | - |

SEASON

| NAME | Description | Value | U.M. |
|---------------|---|--------|------|
| Season | Control unit operation for summer or winter logic | Winter | - |

COMMUNICATION

| NAME | Description | Value | U.M. |
|--------------------------|-----------------------------|-------|------|
| OffLine Rec. Time | Delay time between attempts | 60 | msec |
| Retry Number | Number of attempts | 3 | - |
| Time Out SL | Requested delay time | 500 | msec |
| Time Alarm SL | Alarm delay time | 120 | sec |

SLAVE UNIT

| NAME | Description | Value | U.M. |
|----------------|--|-------|------|
| Max Ui | Maximum number of slave control units configured | 2 | No. |
| Present | Primary control unit/slave active | Yes | - |
| Present | Secondary control unit/slave active | Yes | - |

S0 SUPERVISOR

| NAME | Description | Value | U.M. |
|-------------------|-----------------------------|-------|------|
| Ident. No. | Master unit address | 1 | No. |
| Speed | Data transmission speed | 19200 | bps |
| Prot | Communication protocol used | pLan | - |

S1 SUPERVISOR

| NAME | Description | Value | U.M. |
|-------------------|-----------------------------|-----------|------|
| Ident. No. | Master unit address | 1 | No. |
| Speed | Data transmission speed | 19200 | bps |
| Prot | Communication protocol used | ModBusExt | - |

S2 SUPERVISOR

| NAME | Description | Value | U.M. |
|-------------------|-----------------------------|------------|------|
| Ident. No. | Master unit address | 1 | No. |
| Speed | Data transmission speed | 19200 | bps |
| Prot | Communication protocol used | MASTER 485 | - |

MASTER TYPE

| NAME | Description | Value | U.M. |
|----------------------|--|-----------|------|
| Master Device | Indicates the configuration of the control unit | WI-Master | - |
| T.M. | T.M. communication parameter: Old / New. IT MUST NOT BE MODIFIED | - | - |
| Time OffLine | Delay time before declaring the PC offline | 5 | min |



| PRODUCTION | | | |
|----------------------|--|------------------|------|
| NAME | Description | Value | U.M. |
| Type | Heat source type (Chiller + Boiler or Heat pump) | Chiller + Boiler | - |
| En.SwitchProd | Enable heat source change (if present) for low outdoor temperatures | NO | - |
| Temp. Switch | Minimum temperature for activating the switch with the secondary energy source | 10 | °C |
| Start Prod | Production start time after the energy request | 10 | sec |
| Start Pump | Pump start time after the energy request | 45 | sec |
| Shut-off Pump | Pump shut-off time after have fulfilled the energy request | 180 | sec |

| SANITARY FUNCTION | | | |
|---------------------|--|-------|------|
| NAME | Description | Value | U.M. |
| Enable | Enable function | NO | |
| T_set | Setpoint temperature | 55 | °C |
| delta_T | Temperature variation | | |
| SEL:PROD_SUM | Selects the energy source to start domestic water function in summer | | |
| SEL:PROD_WIN | Selects the energy source to start domestic water function in winter | 5 | °C |

| INTEGRATION FUNCTION | | | |
|------------------------|-----------------------|-------|------|
| NAME | Description | Value | U.M. |
| Enable | Enable function | NO | |
| Delay | Delay | 5 | min |
| Temp. Threshold | Threshold temperature | 0,5 | °C |

| ALTERNATING FUNCTION | | | |
|----------------------|--|-------|-------|
| NAME | Description | Value | U.M. |
| Enable | Enable function | NO | |
| Delay timer | time beyond with the production source change is performed | 10 | hours |

| DIGITAL INPUTS | | | |
|----------------|-----------------|-------|------|
| NAME | Description | Value | U.M. |
| DI1 | Digital input 1 | - | - |
| DI2 | Digital input 2 | - | - |
| DI3 | Digital input 3 | - | - |
| DI4 | Digital input 4 | - | - |

| ENABLE ALARMS | | | |
|---------------|--|-------|------|
| NAME | Description | Value | U.M. |
| Delay | Delay time before setting off the alarms | 30 | sec |
| Buzzer | Enable buzzer | NO | - |

| TIMER | | | |
|---------------------------|--|-------|------|
| NAME | Description | Value | U.M. |
| Main Delay | Delay time before automatically returning to the main screen | 5 | min |
| Switch-off Display | Delay time before the display lighting turns off | 5 | min |

| DELIVERY TEMPERATURE | | | |
|----------------------|---------------------------------------|-------|------|
| NAME | Description | Value | U.M. |
| Offset Win | Delivery temperature offset in winter | 5 | °C |
| Offset Sum | Delivery temperature offset in summer | 5 | °C |



| MIXING VALVE | | | |
|----------------------|--------------------------------------|-------|------|
| NAME | Description | Value | U.M. |
| Minimum Volt. | Minimum voltage for the mixing valve | 0 | V |
| Max volt. | Maximum voltage for the mixing valve | 10 | V |
| PB | Proportional band | 5 | °C |
| IT | Integration time | 30 | sec |
| DB | Dead band | 0,4 | °C |
| K | Approach sensitivity | 5 | - |

| PASSWORD | | | |
|------------------|------------------------|-------|------|
| NAME | Description | Value | U.M. |
| Technical | Password configuration | 9876 | - |

| LANGUAGE | | | |
|-----------------|------------------------|---------|------|
| NAME | Description | Value | U.M. |
| Language | Language configuration | Italian | - |

I/O BOARD SUMMARISING CONFIGURATION

This table summarises the descriptions of the inputs and outputs and includes a brief description of their function.

|  | | INPUT/OUTPUT BOARD WI-Master | |
|--|--------------------------------|---|--|
| CONNECTOR | DEFAULT CONTACT | DESCRIPTION | |
| Digital inputs | | | |
| D11 - GND | Configurable | <ul style="list-style-type: none"> • Chiller alarm • Boiler alarm • LT request • HT request • Sanitary System • General On-Off • Season | |
| D12 - GND | Configurable | | |
| B7- GND | Configurable | | |
| B8- GND | Configurable | | |
| Analogue inputs | | | |
| B6- GND | Outdoor temperature | Outdoor temperature sensor | |
| B5- GND | Delivery temperature | Delivery temperature sensor | |
| B4- GND | Sanitary temperature | Sanitary system delivery temperature sensor | |
| Digital outputs | | | |
| NO1 - C1 | Chiller or Heat pump | Energy production activation | |
| NO2 - C2 | Boiler or second energy source | Energy production activation | |
| NO3 - C3 | Main pump | Main pump activation | |
| NO4 - C3 | Sanitary System | Sanitary system pump activation | |
| NO5 - C3 | HP2 | Secondary heat pump activation | |
| NO6 - C3 | HT Pump | High temperature pump activation | |
| NO7 - C3 | Season | Contact by season: - open = winter - closed = summer | |
| Analogue outputs | | | |
| Y2 - GND | Mixing valve | Analogue output for 0-10V mixing valve | |

CLICK | SCAN



qr.rdz.it/?qr=P450

FAG0EA003BZ.01
09/2020



RDZ S.p.A.

🏠 V.le Trento, 101 - 33077 SACILE (PN) - Italy

☎ Tel. +39 0434.787511 📠 Fax +39 0434.787522

✉ info@rdz.it 🌐 www.rdz.it

**COMPANY WITH
QUALITY SYSTEM
CERTIFIED BY DNV GL
= ISO 9001 =**